

## **Charcoal production environmental performance**

K. Kļaviņa\*, K. Kārkliņa and D. Blumberga

Riga Technical University, Faculty of Power and Electrical Engineering, Institute of Energy Systems and Environment, Āzenes st. 12/1-616, LV1048 Riga, Latvia;

\*Correspondence: krista.klavina@rtu.lv

**Abstract.** Charcoal is a well-known material obtained through thermal conversion of different types of biomass in an anoxic environment. The greatest share of the overall charcoal amount is produced in inefficient batch pyrolysis chambers. Thus contribution in an in-depth charcoal production process research for process optimization is of great importance. In this study an industrial experiment of charcoal production in a continuous up-to-date retort is performed. The selected industrial object has a high level of automation and process control. The retort is connected to a continuous monitoring system that records and stores the process parameter values. Apart from the process control parameter measurements attention has to be paid to the charcoal production plant pollution as this industry often gets contradictory attention towards its environmental performance. The air pollution is evaluated by air quality measurements at the production facility site. The obtained experimental results from an industrial facility with a state-of-the-art technology give an opportunity to evaluate the potential of the charcoal industry to be a sustainable player in the renewable energy market.

**Key words:** industrial experiment, sustainable energy, production, emissions.

### **INTRODUCTION**

Historically the introduction of charcoal led to the development of energy intensive industry establishment, such as glass production and metal smelting as no other energy source at the time could produce enough heat. These industries expanded rapidly and were followed by an extensive use of biomass and wildwood clearance. Many areas met a faster growing industry than the availability of the energy resource. This led to a rapid switching from charcoal to fossil fuels.

Since the beginning of an intensive use of fossil fuels the global greenhouse gas (GHG) emissions have grown to 49.5 giga tonnes of carbon dioxide equivalents in the year 2010 (Victor et al., 2014). GHG emission regulations, programs and policies have taken place and are further expected in order to mitigate the climate change caused by the elevated GHG levels in the atmosphere. The most significant actions have taken place in the past two to three years (Bhander et al., 2014). The Intergovernmental Panel on Climate Change (IPCC) in its Fifth Assessment Report has included the use of biochar as one of the tools for GHG emission reduction. Biochar is charcoal when specifically used as a soil amendment. Using biochar as a soil amendment increases biomass productivity and isolates carbon dioxide from the atmosphere by locking it in the soil (Smith et al., 2014). Some promising research has been done in relation to the use of charcoal as a feasible replacement of fossil fuels by creating fuel blends with an addition

of hardwood derived charcoal to coke in iron-ore sintering thus decreasing the GHG emissions from this industry (Ooi et al., 2011).

The charcoal production feed can be a wide range of materials. Different types of biomass feed lead to the production of different charcoal grades – basic grade biochar, premium grade biochar and charcoal. The used biomass can be starting from biodegradable waste from local waste collection services to hardwood (Schmidt et al., 2012). The use of biodegradable waste for production of valuable materials and energy is highly recommendable in order to reach the EU targets for minimization of the share of landfilled biodegradable waste as well as to avoid resource scarcity (Pubule et al., 2014).

Charcoal is produced in slow pyrolysis carbonisation process. The charcoal yield being dependent on such process parameters as the final temperature, the biomass particle size, the heating rate and the reaction atmosphere (Elyounssi et al., 2012). Traditionally charcoal is made in small, simple batch-type kilns where the parameter management and control is very limited. In the early 1940's the most successful charcoal production technologies were developed - the Lambiotte and SIFIC process. This is a continuous carbonization process where the retort is filled continuously with wood from the top, while downstream simultaneously carbonisation takes place. The cooled charcoal is removed from the bottom. The process is energy autonomous gaining the necessary heat from burning gases attained from pyrolysis. The gases go through a condenser and afterwards are blown in the bottom of the retort where it cools the fresh charcoal while preheating the gases (Vertes et al., 2010). This technology has much higher process control and it offers the possibility of producing charcoal more efficiently and with higher increased yields than the traditional batch methods. This leads to the conclusion that with an increased interest of charcoal production this kind of technologies have to be evaluated from the environmental performance aspects.

This case study is carried out for a Lambiotte type retort producing charcoal from hardwood in Latvia. The hardwood (roundwood) in the form of firewood is prepared on the production facility premises, it includes log sawing, cleaving and drying. The drying of the firewood is crucial for proper functioning of the retort torch, where the excess pyrolysis gases are burnt before emitting to the atmosphere. The fresh wood is received with around 55% moisture content, while the technological process requires the moisture content of the input fuel to be below 25%. The drying takes place in four chamber dryers heated with wood-fuelled water boilers.

The retort is operated under experimental conditions in order to carry out the relevant measurements that describe the production facilities' environmental performance regarding the emissions. The discovered results can be used to evaluate whether there is place for charcoal production in an economically developed country where the environmental performance is of high importance, and it is strictly regulated.

## **MATERIALS AND METHODS**

Evaluating the whole production process stages the main emission sources are distinguished. The technological scheme of the charcoal production process in the studied facility is illustrated in Fig. 1.

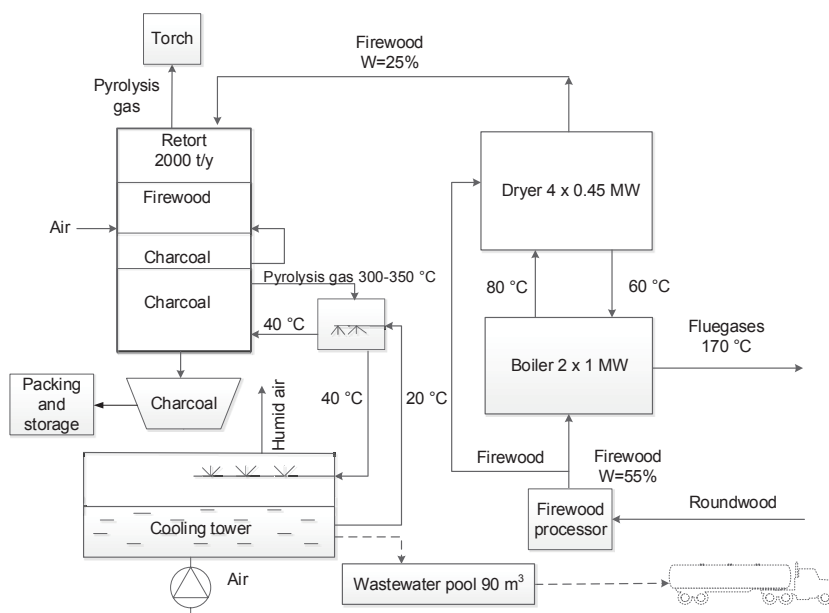

**Figure 1.** Technological scheme of the production facility using Lambiotte SIFIC retort.

The measurements at the production facility are conducted according to the corresponding Standard Method. The distinguished emission sources, emission types and the selected methods for the emission evaluation measurements are summarized in Table 1.

**Table 1.** The main emission types, sources and the measurement procedures

Emission type	Emission source	Method
wastewater (oil product hydrocarbons index)	cooling tower	LVS EN ISO 9377-2:2001
noise	firewood processor, fans, aspiration system, vibrating screener, firewood conveyor	LVS ISO 1996/2-2008
odours	boiler stack, retort	LVS EN 13725:2004
particulate matter (in stack gases; surrounding area)	boiler stack, retort, packing and forwarding of charcoal	LVS ISO 9096:2004/TC1:2007 PД 52.04.186-89 (5.2.6.): 1989
NO <sub>x</sub>	boiler stack, retort	LVS ISO 10849:2001
CO	boiler stack, retort	LVS EN 15058:2006
CO <sub>2</sub>	boiler stack, retort	ISO 12039:2001
volatiles organic compounds VOC (total; qualitative analysis)	boiler stack, retort	LVS EN 12619:2013 NIST 2008 MS LIB cat.NrG1033A Revision Jun 2010

The measurements are made during the period when the manufacturing process has reached a steady operating mode and the settings are adjusted. The measurements are carried out by an accredited laboratory according the research plan. The measurement location is described in Fig. 2.

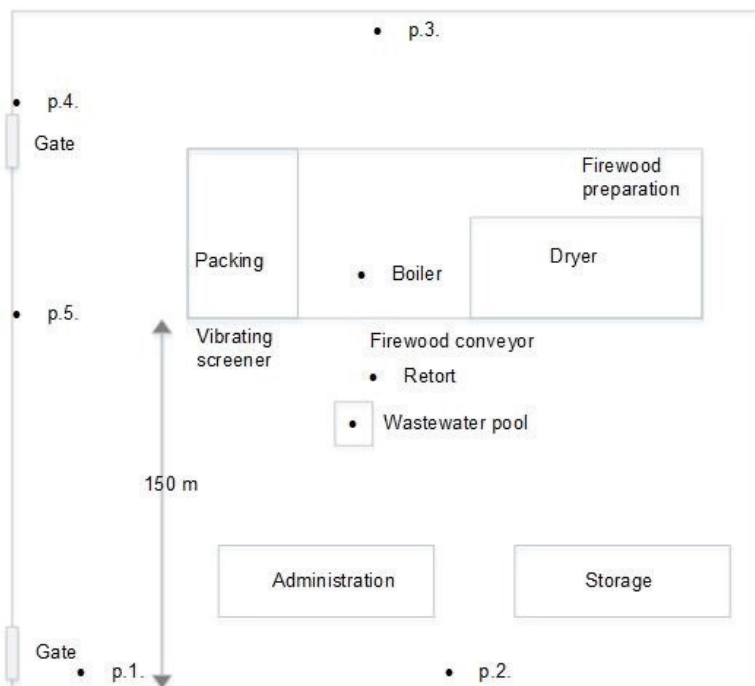

**Figure 2.** Measurement locations in the factory territory.

The measurement locations in Fig. 1 are marked with a dot. The locations p.1 to 5 mark the places where the samples for the particulate matter in the surrounding area, odour and noise determination are taken.

## RESULTS AND DISCUSSION

The industrial experiment at the charcoal production facility took place for 22 days, including the material preparation, process set-up and maintenance. The environmental pollution monitoring was carried out in two separate takes. The obtained results are discussed regarding the legislation requirements and the set thresholds in Latvia. Subdivision according to the specific emission output is used.

### **Wastewater**

There are several types of wastewater created in the facility – domestic wastewater from the administrative buildings, rainwater and the wastewater that is formed in the cooling circuit. The cooling waters are used repeatedly and have to be utilised rarely.

The hydrocarbon index is determined for a sample of the cooling wastewater, returning the value of  $3.6 \pm 1.4 \text{ mg L}^{-1}$ . The result characterizes the water after around

twenty days of operation. According to UNEP (2000) the hydrocarbon oil index environmental limit is 0.01 mg L<sup>-1</sup> while for the Offshore petroleum activities it is 40 mg L<sup>-1</sup> (Department of Energy & Climate Change, 2014) but for example in Massachusetts the upper concentration limit in groundwater is 50 mg L<sup>-1</sup>. These wastewaters have to be either handled by an appropriate authority or the production facility have to ensure an appropriate industrial wastewater pre-treatment meeting the centralized wastewater operator requirements before transition (Cabinet of Ministers, 2002).

### Noise

The noise measurements are carried out in three different charcoal factory production states in a steady operation mode. The ongoing processes and active noise sources while taking the measurements, and the measurement results are described in the Table 2.

**Table 2.** Operation modes and the sound pressure levels

	System operation mode			L <sub>day</sub> , dB(A)
	1	2	3	
firewood processor	<input checked="" type="checkbox"/>	<input checked="" type="checkbox"/>	<input checked="" type="checkbox"/>	
dryer fans	<input checked="" type="checkbox"/>	<input checked="" type="checkbox"/>	<input checked="" type="checkbox"/>	
packing	<input checked="" type="checkbox"/>	<input checked="" type="checkbox"/>	<input checked="" type="checkbox"/>	
retort fans	<input checked="" type="checkbox"/>	<input checked="" type="checkbox"/>	<input checked="" type="checkbox"/>	
vibrating screener	<input checked="" type="checkbox"/>	<input checked="" type="checkbox"/>	<input type="checkbox"/>	
firewood conveyor	<input checked="" type="checkbox"/>	<input type="checkbox"/>	<input type="checkbox"/>	
L <sub>Aeq,T</sub> measurement location p.1., dB(A)	50.1	47.5	45.2	47.2 ± 3.8
L <sub>Aeq,T</sub> measurement location p.2., dB(A)	53.4	53.0	49.5	51.8 ± 3.8

L<sub>Aeq,T</sub> – weighted measured continuous sound pressure level during the time period T, dB(A)

L<sub>day</sub> – weighted estimated continuous sound pressure level, taking into account all the days of the year (as a daily share), dB(A).

The measurement locations mentioned in Table 2 correspond to those depicted in Fig. 2. These locations are chosen because of the sound corridors formed by the buildings in the sound transmission route. The direction of the measurements from the sound sources is selected towards the closest noise recipient – a residential homestead immediately after the factory border.

The national noise limit for individual residential house building areas in Latvia for the day (7.00 to 19.00) period is 55 dB(A), for the evening (19.00 to 23.00) period 50 dB(A), and the night (23.00 to 7.00) period 45 dB(A) (Cabinet of Ministers, 2014a). Thus it can be observed that during the day period the charcoal production facility under different operation modes does not exceed the thresholds. The given measurements do not give a definite assessment for the evening and night periods though, because during these times the firewood processor is not operated and gives an unknown noise reduction. Anyway even if the factory would work at the same operation modes during the night period the sound levels would be just slightly elevated and could be easily reduced by introducing simple cost-effective sound barriers.

## Odours

The odours are measured in the factory surroundings where the measurement includes both odour sources – the stack gases from the boiler and the effluents from the charcoal production retort. The odour measurement methods detection limit is  $11 \text{ OU}_E \text{ m}^{-3}$ . In the territory measurement does not register a result – meaning that the odour is less than  $11 \text{ OU}_E/\text{m}^3$ . A disagreement with the legislation is faced, where the odour target value for an hour is  $5 \text{ OU}_E \text{ m}^{-3}$  since 17/12/2014 (Cabinet of Ministers, 2014b) but the available monitoring technologies do not offer measurements with an appropriate measurement range.

## Emissions to air

The main emission sources are the retort, the boiler and the charcoal transportation and packaging processes. Three separate measurements are carried out, one in the factory surroundings, another at the boiler stack, and the third at the retort torch.

The point source emission measurements from the boiler stack include the concentration of nitrogen oxides ( $\text{NO}_x$ ), carbon monoxide (CO) and PM in the flue gases. The measured values and the corresponding legislative limits (Cabinet of Ministers, 2013) are gathered in Table 3.

**Table 3.** Boiler emission review

	$\text{NO}_x, \text{mg m}^{-3}$	$\text{CO}, \text{mg m}^{-3}$	$\text{PM}, \text{mg m}^{-3}$
Emission limits for average combustion plants up to 10 MW, solid fuels (biomass)*	600	2,000	1,000
Measurement results	$12 \pm 2$	$2,260 \pm 300$	$76 \pm 8$

\* the values are indicative as the regulations govern biomass boilers starting from 5 MW. The nominal capacity of the boiler used in the charcoal factory is 1 MW.

The boiler emission evaluation indicates that while its environmental performance is tolerable the high concentration of CO in the stack gasses indicate high losses of energy content as it could still be further reduced to carbon dioxide ( $\text{CO}_2$ ) and return valuable heat. General boiler efficiency improvements are strongly advisable.

The point source emissions measured from the charcoal production retort include  $\text{CO}_2$ , CO,  $\text{NO}_x$ , and the total VOS's. The measurements at the retort presented several significant obstacles. First of all the construction of the technology does not offer a place for a proper measurement (considering the pipe diameters before and after the measurement point with a stabilised gas flow), secondly the effluent gases before ignition in the torch contain different tars and water droplets that can be harmful for the measurement equipment, and thirdly some of the measured parameter values do not match the equipment measurement ranges (the gas flow rate is detected to be smaller than the minimum value of the equipment measurement range, the total VOC concentration exceeds the concentration accepted by the qualitative analysis of the VOC). This leads to the measurements being made 0.1 m from the top of the torch. Thus the measurement values characterise partly burnt effluent gasses. After the measurement point a complete combustion takes place, as the combustion process is well oxygenated. The measurement values are presented in Table 4.

**Table 4.** The measured parameter values at the retort

Parameter	Value and the uncertainty
CO <sub>2</sub> , vol.%	2.8
CO, mg m <sup>-3</sup>	1,940 ± 600
NO <sub>x</sub> , mg m <sup>-3</sup>	82 ± 14
total VOC, mg <sub>C</sub> m <sup>-3</sup>	650 ± 20

The emissions from the point source of the retort are not directly regulated, but are subjected to the Natural resource tax according to (The Saeima, 2005). According to EPA (1995) the combustion of the effluent pyrolysis gases reduces the emissions for at least 80%.

The air quality measurement samples at the surrounding area that characterises the influence of the point sources to the surrounding areas are taken in a 2 m height at the measurement locations from p.3. to p.5. The emissions from charcoal handling and packing are included in the overall surrounding emissions and are not measured separately. The measured parameters are the particulate matter (PM), and the qualitative and quantitative analysis of the VOC. The measurements are carried out according to the wind direction. The meteorological conditions during the measurements: air temperature +2 °C, wind velocity 0.8 m s<sup>-1</sup>, air relative humidity 60%, atmospheric pressure 763 mmHg. The measurement period includes the loading of the firewood in to the trolley and retort, product handling, screening and conveying to the packing line.

The PM measurement results according to the particulate size are described in Table 5.

**Table 5.** Measurement results for the PM in air

Measurement No	PM <sub>10</sub> , µg m <sup>-3</sup>	PM <sub>2.5</sub> , µg m <sup>-3</sup>	PM <sub>total</sub> , µg m <sup>-3</sup>
1	-	-	650
2	-	11	665
3	22	21	78

A similar disagreement as in the odour measurements is met here, because the accredited laboratory offers only the measurement of the total PM while the legislation regulates the permissible levels of PM<sub>10</sub> and PM<sub>2.5</sub> with the according values of 40 (for the annual calculation period) and 25 µg m<sup>-3</sup> (Cabinet of Ministers, 2009). Thus additional measurements (No 2 and 3) are carried out by the authors to evaluate the regulated sphere. The results fall within the regulatory limits.

The qualitative analysis of VOC's in the surrounding air indicates the presence of the following elements:

- ✓ acetone
- ✓ benzene
- ✓ toluene
- ✓ p-Xylene
- ✓ 1,3,5- trimethyl-benzene
- ✓ naphthalene
- ✓ nonanal
- ✓ decanal

The quantitative VOC analysis report a total concentration of 0.3 mg m<sup>-3</sup> with a 0.2 mg m<sup>-3</sup> uncertainty (Cabinet of Ministers, 2009). From the above list the Latvian legislation regulates only the weekly concentration of toluene with the value of 0.26 mg m<sup>-3</sup>. It can be assessed that this threshold is not exceeded as the total concentration includes additional seven elements and it is doubtful that toluene would compile the largest share. Though some improvements should be introduced to the measurement uncertainty boundaries to endorse this statement.

## CONCLUSIONS

The study carried out for experimental operation of a real life charcoal factory gives a great example of a successful collaboration of a private company and a scientific institution. An accredited laboratory was involved as a third party, on the one hand attracting an independent third party to perform the measurements give more credible results while on the other hand poses some difficulties in the compliance with the experimental design.

The discussed results indicate that a modern charcoal production facility can be sustainable and without a significant environmental impact in sense of its emissions. However some deeper environmental performance evaluation could take place with the availability of measurement equipment with a wider measurement range, higher precision and more suitable for measurements in a charcoal factory. Also additional research could be performed with a wider perspective evaluating the sustainability impact from biomass use for carbonisation, as the historical charcoal use lead to an extensive reduction of forest area and is still connected with deforestation in some locations. Introduction of a lower grade biomass for charcoal production and the consequent changes in the environmental performance of the factory should be studied.

This far the research gives a good perspective for the development of a sustainable charcoal production sector in Latvia. It is important to remember though that the overall environmental performance of every specific facility is highly influenced by the individual management of the company, but the available technology offers a possibility for a production that can fulfil the environmental requirements. The results were also presented to the Ministry of Environmental Protection and Regional Development of the Republic of Latvia in order to provide a scientific background for decision-making.

ACKNOWLEDGEMENTS. The work has been supported by the National Research Program 'Energy efficient and low-carbon solutions for a secure, sustainable and climate variability reducing energy supply (LATENERGI)'.

## REFERENCES

- Bhander, G., Hutson, N., Rosati, J., Princiotta, F., Pelt, K., Staudt, J., Petrusa, J. 2014. GHG mitigation options database (GMOD) and analysis tool. *International Journal of Greenhouse Gas Control* **26**, 1–8.
- Cabinet of Ministers 2002. No.34 Terms of emissions of pollutants in water. *Latvijas Vēstnesis* **16** (2591).
- Cabinet of Ministers 2009. No.1290 Air Quality Regulations. *detection methods as well as the procedures for restricting the spread of odors* **182**(4168).



- Cabinet of Ministers 2013. No.187 Procedures for preventing, limiting and controlling air pollutant emissions from incinerators. *Latvijas Vēstnesis* **73**(4879).
- Cabinet of Ministers 2014a. No.16 Noise Assessment and Management Procedures. *Latvijas Vēstnesis* **16**(5075).
- Cabinet of Ministers 2014b. No.724 Regulations on detection methods as well as the procedures for restricting the spread of odours caused by a polluting activity. *Latvijas Vēstnesis* **250** (5310).
- Department of Energy & Climate Change 2014. *Methodology for the Sampling and Analysis of Produced Water and Other Hydrocarbon Discharges*, London, 97 pp.
- Elyounssi, K., Collard, F.-X., Mateke, J.N., Blin, J. 2012. Improvement of charcoal yield by two-step pyrolysis on eucalyptus wood: A thermogravimetric study. *Fuel* **96**, 161–167.
- EPA Environmental Protection Agency 1995. *Emissions Factor Documentation for AP-42 Section 10.7 Charcoal*, 29 pp.
- Ooi, T.C., Thompson, D., Anderson, D.R., Fisher, R., Fray, T., Zandi, M. 2011. The effect of charcoal combustion on iron-ore sintering performance and emission of persistent organic pollutants. *Combustion and Flame* **158**, 979–987.
- Pubule, J., Kamenders, A., Valtere, S., Blumberga, D. 2014. Cleaner production in biowaste management. *Agronomy Research* **12**(2), 575–588.
- Schmidt, H. P., Abiven, S., Kammann, C., Glaser, B., Bucheli, T., Leifeld J. 2012. *European Biochar Certificate, Guidelines for biochar production*. 18 pp.
- Smith, P., Bustamante, M., Ahammad, H., Clark, H., Dong, H., Elsiddig, E.A., Haberl, H., Harper, R., House, J., Jafari, M., Masera, O., Mbow, C., Ravindranath, N.H., Rice, C.W., Robledo Abad, C., Romanovskaya, A., Sperling, F., and Tubiello, F. 2014. Agriculture, Forestry and Other Land Use (AFOLU). In Edenhofer O., Pichs-Madruga R., Sokona Y., Farahani E., Kadner S. et al. (eds): *Climate Change 2014: Mitigation of Climate Change. Contribution of Working Group III to the Fifth Assessment Report of the Intergovernmental Panel on Climate Change*, Cambridge University Press, Cambridge, UK and NY.
- The Saeima 2005. Natural Resources Tax Law. *Latvijas Vēstnesis* **209** (3367).
- UNEP 2000. *Update report by the technology and economic assessment panel on alternatives for ozone-depleting substances used to extract oil and grease from water*. Ouagadougou.
- Vertes, A.A., Qureshi, N., Blaschek, H.P. Yukawa, H. 2010. *Biomass to Biofuels: Strategies for Global Industries*. John Wiley & Sons, Hoboken, 559 pp.
- Victor, D.G., Zhou, D., Ahmed, E.H.M., Dadhich, P.K., Olivier, J.G.J., Rogner, H-H., Sheikho K., and Yamaguchi M. 2014. Introductory Chapter. In Edenhofer, O., Pichs-Madruga R., Sokona Y., Farahani E., Kadner S. et al. (eds.): *Climate Change 2014: Mitigation of Climate Change. Contribution of Working Group III to the Fifth Assessment Report of the Intergovernmental Panel on Climate Change*. Cambridge University Press, Cambridge, UK and NY.