

Energetic balance of autonomous hybrid renewable energy based EV charging station in winter conditions

V. Osadcuks*, A. Pecka and R. Selegovskis

Faculty of Engineering, Latvia University of Agriculture, J. Cakstes blvd. 5., LV-3001 Jelgava, Latvia; *Correspondence: vtl@tvnet.lv

Abstract. The paper presents an experimental research on energetic balance of an autonomous hybrid renewable energy based electric vehicle (EV) charging station. The experimental charge station is located in the central part of Latvia in Jelgava city. The station is built using standard small-scale hybrid power system equipment: 24 V 300 Ah lead-acid battery, 2 kW photovoltaic array, 300 W wind generator, hybrid charge controller and 1.6 kW inverter. The station is capable to perform mode 1 EV charging (220 V, 50 Hz, up to 1.6 kW). The aim of the research is to evaluate the operational possibilities, technical self-consumption and overall energy balance of the renewable resources based station during a winter period. Analysis on available power for EV charging, self-consumption and affecting environmental factors during a 6-day period is performed. The time period was chosen to include days with temperatures below and above zero and various levels of solar irradiation. Conclusions about possibilities and usefulness of winter-period exploitation are given.

Key words: renewable resources, electric vehicle charging station, winter conditions.

INTRODUCTION

Recent developments and the overall cost reduction of renewable energy equipment allow considering autonomous renewable energy based power supply systems as an alternative to a power grid connection. One of the cases where such autonomous power systems can be effectively used is the electric vehicle (EV) charging infrastructure in remote places without power grid coverage or with low quality connections e.g. intercity roads, remote rural places, tourist sites, national parks, etc. (Hongxing & Wei & Chengzhi, 2009). Technical and economical effectiveness of renewable energy generators is affected by annual weather conditions. In winter months in the central part of Latvia average minimum air temperature is – 6 °C (Climate information..., 2012), and additional heating of electrical equipment may be necessary. A crucial part in every autonomous power system is energy storage equipment or batteries. One of the most cost-effective energy storage technologies for stationary backup and standalone power system applications nowadays is lead-acid chemical battery technology with a cost of 50–150 EUR per kWh and lifespan up to 2,000 cycles with 70% depth of discharge (Divya & Ostergaard, 2009, Daim et. al., 2012). It is a well-known fact that operating lead-acid batteries at higher temperatures will reduce the life and operating at lower temperatures will reduce the efficiency (Çadırcı & Özkazanç, 2004). Also there is a risk of electrolyte freezing for VRLA batteries at low discharge rates when specific gravity of the electrolyte can become less

than 1,100 and the electrolyte will freeze at approximately $-6.7\text{ }^{\circ}\text{C}$ (C&D VRLA battery..., 2012). Therefore operating conditions should also be taken into account for the batteries. The aim of the research is to evaluate operation possibilities, technical self-consumption and overall energy balance of a small-scale autonomous hybrid wind-solar EV charging station during the winter period in Latvia by using only off-the-shelf equipment currently available on market.

MATERIALS AND METHODS

The experiments were performed on a standalone small-scale electrical hybrid power system (HPS) designed for off-grid low power EV charging. A simplified electrical circuit of the experimental setup is shown in Fig. 1. The system uses the central DC bus topology with parallel connection of generator, load and battery with nominal system voltage 24 V. The main components of the system are 2 kW PV array (10 Kioto KPV 195 PE modules) positioned to the South at 62.88° tilt to the horizon, Senwey Energy 300 W wind generator with 3-blade turbine, permanent magnet synchronous machine and dedicated charge controller (see Fig. 2 and 3), two series-connected ABT TM12-510W 12 V 100 Ah VRLA (Valve Regulated Lead Acid) batteries, hybrid solar charge controller Steca Power Tarom 2,140 and MeanWell TN/TS-1500 sine wave inverter. Maximum system output for EV charging is 1,600 VA.

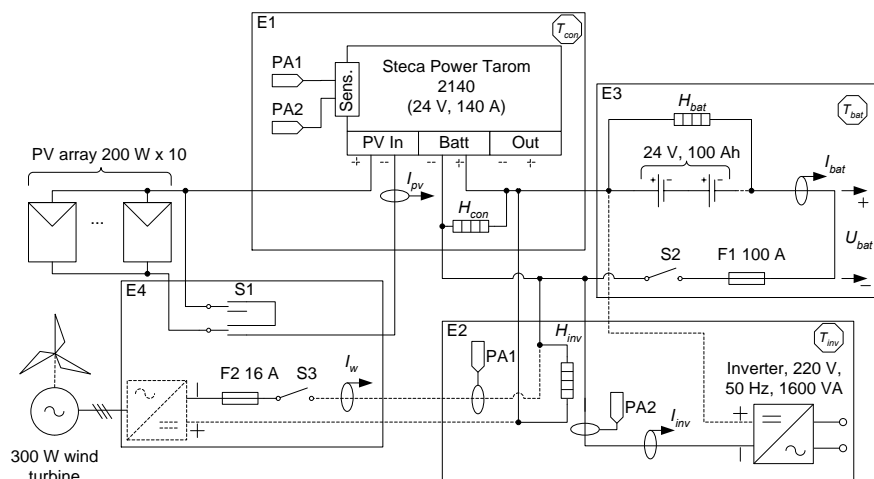

Figure 1. Experimental setup, measured parameters: I_{pv} – current from photovoltaic array; I_{bat} – battery current (below 0 – discharge, above 0 – charge); I_w – current from wind generator; I_{inv} – current to inverter; U_{bat} – system voltage; T_{con} , T_{bat} , T_{inv} – temperatures in enclosures; H_{con} , H_{bat} , H_{inv} – heater states in enclosures.

The equipment is arranged in 4 enclosures. E1 houses hybrid solar charge controller; E2 contains inverter, circuit breakers and energy meters for AC 220 V EV charging and current sensors for the hybrid charge controller; enclosure E3 is for battery placement; E4 contains charge controller for wind generator. The enclosures are made of 1.5 mm steel sheets, sizes of the enclosures (WxHxD) in millimetres are

360 x 330 x 190 (E1), 650 x 450 x 200 (E2) and 700 x 550 x 450 (E3). The enclosures are placed in a closed yard under PV modules array and thus effects of solar radiation and wind are minimal (see Fig. 4).



Figure 2. Two kilowatts PV array of 10 Kioto KPV 195 PE modules.



Figure 3. Vaisala weather station MAWS201 and 300 W wind generator.

A number of parameters of HPS are used for data analysis. Along with the electric measurements meteorological data is used. In our case a portable Vaisala weather station MAWS201 is used to get the meteorological information (see Fig. 3).



Figure 4. Placement of enclosures of electrical equipment: E1 – solar charge controller; E2 – inverter; E3 – VRLA batteries; E4 – dedicated wind turbine charge controller.

The Vaisala weather station is a real-time data source that is used in a variety of weather observation activities. In the current experiments wind speed, temperature and irradiation measurements are used. Station communication interface to other devices is a RS-232. To connect the station with a PC over long distances (approximately 60m) a RS-232 to RS-485 interface converter was used. The RS-485 to USB converter is placed between RS485 terminal and PC for virtual serial port connection which in its turn can be easily used in software for data acquisition. The data from the weather station is obtained every minute and stored in a database server, which is in the same LAN where the PC stands. For the data transferring and database interfacing purposes special software was developed. Experimental data flow diagram is depicted in Fig. 4.

An embedded device for HPS current, voltage and temperature measurements (IUT) was developed.

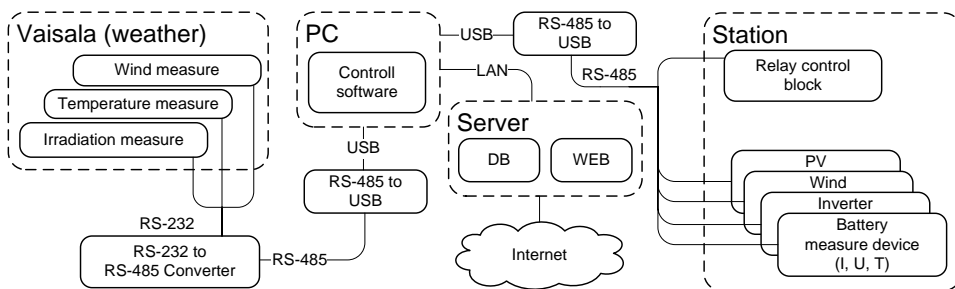

Figure 4. Experimental data flow diagram.

The device is based on PIC24F microcontroller and can read data from sensors and provides communication with a master PC. For current measurement HTFS 200-P Hall-effect contactless current transducer with current dependent analog voltage output is used. Voltage divider directly connected to the voltage source is used for voltage measurement. The electrical measurements are filtered using moving average filter with 1 s period, thus it is possible to filter transients caused by load switching and solar charge controller switching regulation, which is performed at 20 Hz. Integrated digital sensor TSIC 506F used for measurement of temperature (see Table 1).

Table 1. Accuracies of sensors

Source	Measurement	Accuracy +/-	Unit
Vaisala station	temperature	0.3	°C
	wind speed	0.3	m·s ⁻¹
	irradiation	0.2	W·m ⁻²
IUT device	voltage	0.1	V
	current	0.2	A
	temperature	0.1	°C

Three IUT devices are placed in enclosures. The placement of electrical measurement sensors is shown in Fig. 1. In addition enclosures E1–E3 are equipped with heaters for temperature regulation to maintain operating conditions of the housed equipment. One relay control device with three outputs is used for heater management (executing commands from PC and turning on and off the relays); this device is placed in enclosure E2. Temperature sensors are placed in the center of each enclosure to get average readings, but heaters are installed as close as possible to the lower part of the enclosures in order to achieve better convection. It should be noted that due to the sizes of E1 and E2 it was not possible to fully avoid the effect of direct heater radiation on temperature sensor readings. IUT and relay control devices are interconnected with the master using a RS-485 network. A RS-485 to USB converter is used at the PC side. All measurements data is stored in the database server with one-minute interval synchronously with meteorological measurements. Power and energy for further data analysis is calculated by integration of product of system voltage and currents in various parts of the circuit. The master PC also runs a control algorithm, performs current monitoring and relay switching. Progress of experiments and data logged on the server can be accessed through WEB.

The self-consumption of the power system equipment consists of electrical self-consumption and energy needed for regulation of the enclosure's internal temperature. In this research heating is considered only as a temperature regulation option in the winter period for climatic conditions of Latvia. Consumption needed for heating is expressed in heat loss per K according to (1).

$$Q = \frac{A}{\alpha_t^{-1} + \delta \cdot \lambda_d^{-1} + \alpha_A^{-1}} \text{ [W} \cdot \text{K}^{-1} \text{]}, \quad (1)$$

where A – total area of walls of enclosure, m^2 ; α_t – internal surface conductance for the wall, $8.7 \text{ W K}^{-1} \text{ m}^{-2}$; α_A – external surface conductance for the wall, $23 \text{ W} \cdot \text{K}^{-1} \text{ m}^{-2}$; δ – thickness of walls, m ; λ – thermal conductivity of walls, W (K m)^{-1} .

The calculated heat losses per K are 3.15 W for controller enclosure, 6.47 W for inverter enclosure and 11.96 W for battery enclosure. The heat losses are significantly larger than self-consumption of electrical equipment (less than 1 W for controllers and inverter).

Heaters and internal temperature control mode for each enclosure was selected taking into consideration heat losses and operation conditions of the housed equipment. According to datasheets Power Tarom 2140 should not be operated below $-15 \text{ }^\circ\text{C}$, but TN/TS-1500 inverter – below $0 \text{ }^\circ\text{C}$, so keeping these temperature levels in enclosures is mandatory for normal operation of equipment. For batteries minimum charge temperature is $-15 \text{ }^\circ\text{C}$, but discharge temperature $-20 \text{ }^\circ\text{C}$. Operating conditions, calculated temperatures and selected heaters are summarised in Table 2. Temperature control algorithm is performed from master PC (Fig. 4). For the temperature control in all enclosures thermostats are used with setpoints shown in Table 2.

Table 2. Operating temperature in enclosures, selected heaters and thermostat setpoints

Enc.	Housed equipment	Operating temperature, $^\circ\text{C}$	Heater type/power at 24 V	Max. ambient/intern al temperature difference, $^\circ\text{C}$	Min. ambient temperature for selected heaters, $^\circ\text{C}$	Thermostat On/Off temperature, $^\circ\text{C}$
E1	Steca Power Tarom 2140 solar charge controller	-15...60	Ni-Cr heating wire with ceramic coating, 16 W	5.0	-20	1/3
E2	MeanWell TN/TS-1500 sine wave inverter	0...60	Incandescent lamp, 60 W	9.0	-9	1/3
E3	ABT TM12-510W batteries, 24 V, 100 Ah	-10...60 (charge) -20...60 (discharge)	Incandescent lamp, 60 W	4.8	-14.8 (charge) -24.8 (discharge)	-9/-7

Additional temperature control logic was added for batteries. As in Fig. 5, battery capacity at different discharge rates decreases by 0.7–1.6% with ambient temperature decrease by $1 \text{ }^\circ\text{C}$. In absolute terms for the case study it is 1.1 Ah per degree or

approximately 26 Wh with nominal battery voltage at 1 h discharge rate. The temperature effect on lead-acid batteries is studied in more detail in (Çadırcı & Özkazanç, 2004).

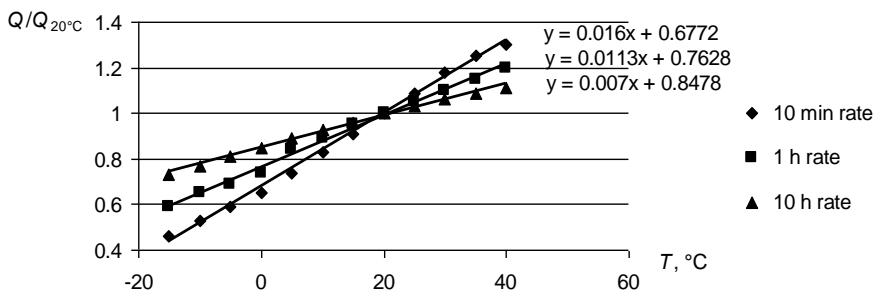

Figure 5. Temperature effect on capacity of TM12-510W expressed in relation to nominal capacity at 20 °C (information from manufacturer’s datasheet).

The control algorithm is shown in Fig. 6. In order to maximise capacity of the battery through the temperature the control algorithm turns on heater in enclosure E3 when excess energy is available from photovoltaic array and/or wind generator.

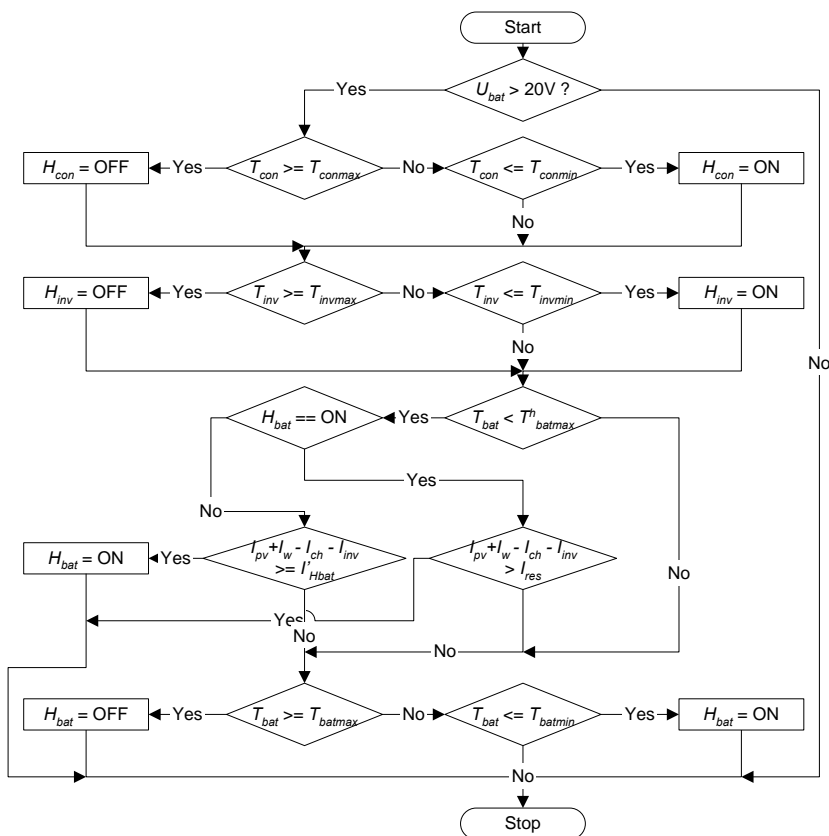

Figure 6. Temperature control algorithm.

If heater Hbat is not turned on yet, available power expressed with currents (voltage is constant for all system components) $I_{pv} + I_w - I_{ch} - I_{inv}$ is compared against calculated current for battery heater I_{Hbat} to find if there is enough current to turn the heater on. I_{Hbat} for given voltage is calculated using heater's U-I curve. If Hbat is already on, the algorithm checks if available current is more than reserved current I_{res} for self-consumption of the rest of the equipment. If available current decreases, Hbat is turned off. I_{res} was set to 0.5 A for the experiments. Maximum temperature allowed in enclosure is 20 °C as it is nominal ambient temperature for the selected battery model. No heating is performed in any enclosure, if battery voltage drops below 20 V.

RESULTS AND DISCUSSIONS

The experiments were performed continuously in a 6-day period from February 6th to February 13th. Experiments were started with a fully charged battery. Operating temperature in enclosures was maintained according to algorithm in Fig. 6 during the period of experiments, except day 3 when experiment on heating transient process was carried out. Meteorological data affecting operation of HPS during the period of experiments is shown in Fig. 7. Average ambient temperature was -0.6 °C, total solar irradiation on horizontal surface was 6 kWh·m⁻², but average wind speed - 2.5 m s⁻², which according to manufacturer's datasheet is the cut-in speed of the wind turbine.

The wind charge controller used in the experiments is operating as a switch and has no voltage step-up function. The controller begins charging only when rotation speed of the wind turbine is enough to raise the output voltage to level required for 12 cells lead-acid battery charging (27–28 V). In conjunction with proportionally greater power of the solar panel array this results in a decrease of the effectiveness of the wind generator in the hybrid small-scale standalone power system. This, in despite of the fact that a special hybrid solar charge controller with a remote sensor (Steca HS200) was used for external current sources. Fig. 8 shows the use of wind energy for battery charging during various meteorological conditions. The scenario shown in the figure confirms the main idea of using a wind generator in a solar power system – with a decrease of solar radiation in cloudy conditions as a rule wind speed increases yet overall low wind speeds resulted in minimal wind generator output (<0.1 kWh) during the period of experiments.

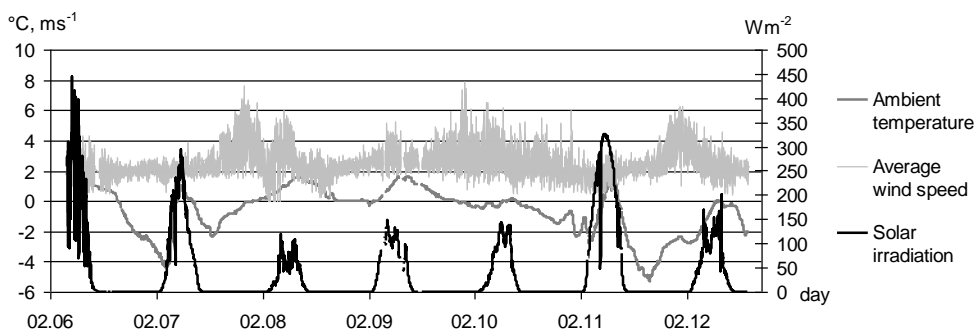

Figure 7. Temperature, wind speed and solar irradiation during experiments.

Before the period of experiments a test was performed to evaluate the real performance of heaters under changing operating voltage conditions, when the batteries are constantly discharged. After transient process the test showed that the difference between ambient and internal temperature of enclosures was 7.3 °C for E1, 12.7 °C for E2 and 4.8 °C for E3. Temperature difference for E3 confirmed the theoretical calculations, but E1 showed 2.3 °C and E2 – 3.7 °C greater temperatures, which can be explained with relatively small sizes of enclosures and close distance between heater and sensor. It should be noted that wind effect during the tests was minimal. Performance of heaters allows the safe use of the system for EV charging at temperatures down to –10 °C, but operation of controlling equipment (without using inverter for charging) down to –20 °C. Total power consumption for heating (including battery enclosure) will be 123 W or 3 kWh of energy per day at nominal system voltage, but if heating is used to keep operating temperature for controller and inverter only – 69 W and 1.7 kWh respectively. This can be decreased by additional heat insulation of enclosures.

Available instant solar horizontal irradiation (I_s), ambient temperature (T_a), system voltage (U_{batt}) and dynamic of internal temperatures of each enclosure for a day with average temperature –1.8 °C are given in Fig. 9. Experiments in daylight confirmed that temperature in the enclosures is significantly affected by indirect solar irradiation; with the heaters turned off it was 3–10 °C above ambient temperature depending on the size of enclosure and solar irradiation.

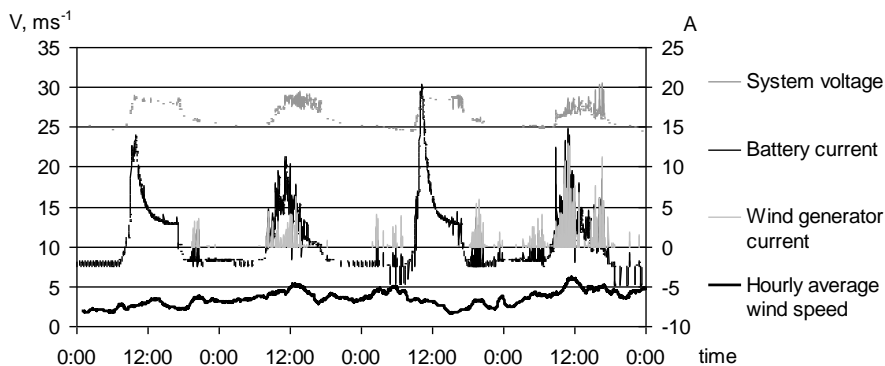

Figure 8. Use of wind energy for battery charging during various meteorological conditions.

During a night temperature in enclosures E1 and E2 was controlled by thermostat, but during daylight battery enclosure E3 was additionally heated using excess energy from photovoltaic panels when it was available. Thus temperature in E3 was 8.1 °C (10 °C above ambient) when the heater was turned off with decrease of solar irradiation and 0.1 °C (0.5 °C above ambient) at its closest point to ambient temperature, allowing to save up to 0.8% of battery capacity in the worst case.

Total produced energy during the period of experiments was 19.7 kWh, 1.8 kWh of which was used for heating of equipment, which was mandatory. In addition 2 kWh of total 17.9 kWh excess energy was used for heating batteries. Energy used for heating depending on daily average temperature is summarised in Fig. 10.

Assuming the worst-case energy amount needed for heating controlling equipment (1.7 kWh per day) it can be concluded that discussed HPS can be operated at temperatures down to $-10\text{ }^{\circ}\text{C}$, but it will take approximately half of the total energy produced for self-consumption during typical winter weather conditions. For a longer period of time and depending on EV charging intensity this will lead to negative energy balance. It should be noted that the same controlling equipment with the same self-consumption can be used with up to 3.5 kW PV array, thus optimal sizing of generating equipment can improve the energetic balance.

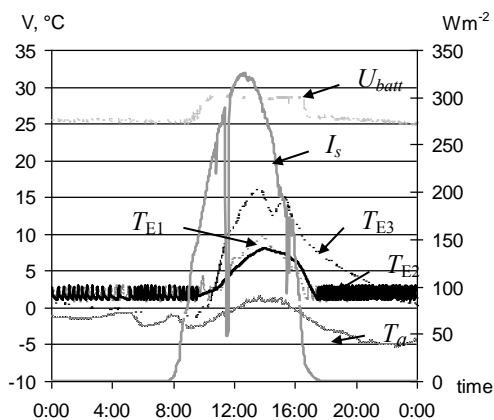

Figure 9. Daily temperature parameter dynamics.

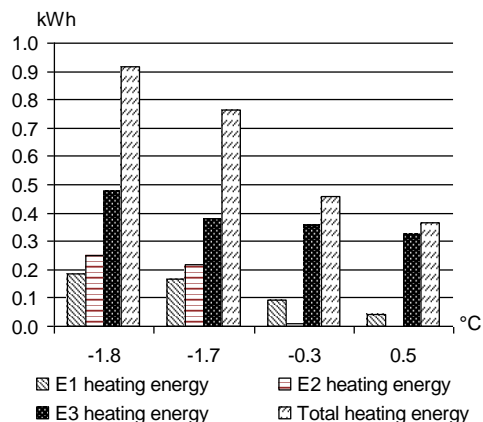

Figure 10. Heating energy depending on daily average temperature.

It should be noted that only standard enclosures without heat insulation were used and arrangement of electrical equipment depending on its function was chosen: DC controlling and AC power equipment in separate enclosures and dedicated enclosure for chemical batteries. Alternatively in order to save the heating energy, electrical equipment could also be placed in a common enclosure, but batteries due to necessity of ventilation and different heat regulation algorithm should be operated only in a separate enclosure in all cases.

CONCLUSIONS

1. Proposed small-scale autonomous hybrid power system for off-grid low power electric vehicle charging using off-the-shelf components can be fully operated at temperatures down to $-10\text{ }^{\circ}\text{C}$, but operation of controlling equipment (without charging function) down to $-20\text{ }^{\circ}\text{C}$.

2. Total worst-case power consumption for maintaining normal operational conditions for controlling and power conversion equipment is 69 W or 1.7 kWh of energy per day at nominal system voltage. This can be decreased by additional heat insulation of enclosures, but ventilation, electrical and fire issues should be considered.

3. Excess energy can be effectively used for additional heating of main lead-acid batteries thus increasing efficiency of the batteries, which is strongly affected by ambient temperature, but longer experiments with full charge/discharge cycles of

batteries are needed to fully evaluate effects of environmental conditions, schedule of energy usage for electric vehicle charging and overall economical reasonability.

4. Mutual sizing of power generating equipment is essential for small-scale hybrid power systems. Output of smaller generator can be used fully only in periods with significant decrease in primary generator output as it was in our case with primary 2 kW photovoltaic array and 300 W generator. Besides optimal power sizing of the generators the problem could be partially solved by using power converters with maximum power point tracking and voltage step-up functions.

ACKNOWLEDGEMENTS. Funding support for this research is provided by the ERAF Project ‘Usage of Electric Energy in Motor Vehicles of Physical Persons’ (No. 2010/0305/2DP/2.1.1.1.0/10/APIA/VIAA/130).

REFERENCES

- Çadırcı, Y. & Özkazanç, Y. 2004. Microcontroller-based on-line state-of-charge estimator for sealed lead–acid batteries. *Journal of Power Sources* **129**, 330–342.
- C&D VRLA battery electrolyte freeze protection. [online][viewed 10.12.2012] Available at: http://www.cdtechno.com/pdf/ref/41_7953_0112.pdf
- Climate information for Riga in Latvia. [online][viewed 10.12.2012] <http://www.climate-zone.com/climate/latvia/celsius/riga.htm>
- Daim, T.U., Li, X., Kim, J. & Simms, S. 2012. Evaluation of energy storage technologies for integration with renewable electricity: Quantifying expert opinions. *Environmental Innovation and Societal Transitions* **3**, 29–49.
- Divya, K.C. & Ostergaard, J. 2009. Battery energy storage technology for power systems-An overview. *Electric Power Systems Research* **79**, 511–520.
- Hongxing, Y., Wei, Z. & Chengzhi, L. 2009. Optimal design and techno-economic analysis of a hybrid solar–wind power generation system. *Applied Energy* **86**, 163–169.