

Effect of conductive ink on transfer characteristics of pressure into electric signal for tactile sensors

J. Volf*, V. Novák and V. Ryzhenko

Czech University of Life Sciences Prague, Faculty of Engineering, Kamýcká 129, CZ165 21 Prague, Czech Republic

*Correspondence: volf@tf.czu.cz

Abstract. The article deals with tactile sensors with circular electrodes in which conductive ink was used as a converter converting pressure into an electric signal. The article briefly describes theoretical background of this issue and presents several appropriate converters, from which the tested ink was selected. The measurement process is described in detail, and subsequently the dependence of resistivity on the thickness of the deposited ink layer is studied and the properties of various setups were compared. Finally, the results are summarized and the main issues are pointed out.

Key words: Conductive elastomer, conductive ink, tactile sensors and transducers.

INTRODUCTION

Up till now the conductive elastomer Yokohama rubber CS57-7RSC was used in the production of tactile sensors (Volf et al., 2009; Trinkl, 2011; Volf et al., 2012). Properties of different polymers are described in (Souza et al., 2005; Soares, 2006). Due to some of its negative properties, such as excessive hysteresis, and due to changes in the design of the Plantograf measuring system, we searched for another type of material for the conversion of the imposed pressure into an electric signal. The decision was to use conductive ink. Conductive inks consist of ink filled with small pieces of conductive particles; we tested inks containing graphite and silver particles. For testing, we obtained four types of conductive inks: KH WS SWCNT (KH Chemicals, Korea) Luxor (Luxor, Taiwan), NGAP FI Ag-4101 (NANOGAP, Spain) and DZT-3K (DZP Technologies, United Kingdom). After preliminary evaluations, the ink DZT-3K has been chosen and used in the measurements since owing to its composition. It could form a relatively high-quality conductive layer. The other inks did not meet the requirements, either they were too thin and they did not form a continuous layer, or they did not adhere to the substrate (first two, both water-based inks) or they were excessively conductive – as the third ink with silver particles as a filler – the resistance of the ink was only in units of Ω . The selected ink uses carbon particles as filler. A possible disadvantage of the conductive ink might be the difficulty to create a compact and stable layer, compared to the conductive rubber (Volf et al., 2006, Trinkl, 2011; Lufinka, 2014).

MATERIALS AND METHODS

Production of DZT-3K ink specimen

The former aim was to apply the ink layer on the electrodes directly. However, the selected ink DZT-3K was unable to create a coherent conductive layer, i.e. to sustain its integrity. Any negligible mechanical load caused the separation of the ink from the electrodes' surface. The measuring method – pushing with a force sensor tip on the ink layer – would not be applicable in this case. Additionally, we observed a certain deformation of the ink layer between the inner and outer electrode.

As this setup proved not to be utilizable, we proceeded to an alternative layout: the selected DZT-3K ink was deposited on the surface of a PET foil and applied to the electrodes similarly as the conductive elastomer. The thickness of the selected PET foil was 0.3 mm. The ink was deposited on the foil by a TG 130 spray gun, which can spray very low amounts of ink and enables fine control of spraying. A unique 12V Škoda 8P0012615A compressor originally used for inflating tyres was used as a compressor. Three thicknesses were selected of the deposited ink layer: 7 μm , 15 μm and 23 μm . The thicknesses were obtained by 6-fold, 12-fold and 18-fold repeated application. The spray applications were performed through a template made of the same foil with 3 mm holes in view of the 2.5 mm outer diameter of the circular electrodes. The thickness of the deposited ink layer was measured with a Mitutoyo SR44x1 digital micrometer with a measuring range of 0–25 mm and accuracy of 0.001 mm.

Shape of the measured electrodes

The dimensions of the measured electrodes are depicted in Fig. 1. The measurements were performed on a scanning matrix comprising circular electrodes with a 2.5 mm diameter. The electrodes were placed on a Cuflex printed circuit board. Conductors were soldered to the outlets of lines and columns which enabled easy choice of a particular electrode. The electrodes are denoted accordingly to their marking 'PD': $\text{OE} = 2.5 \text{ mm}$, $\text{Od} = 0.1 \text{ mm}$, $\text{M} = 0.1 \text{ mm}$.

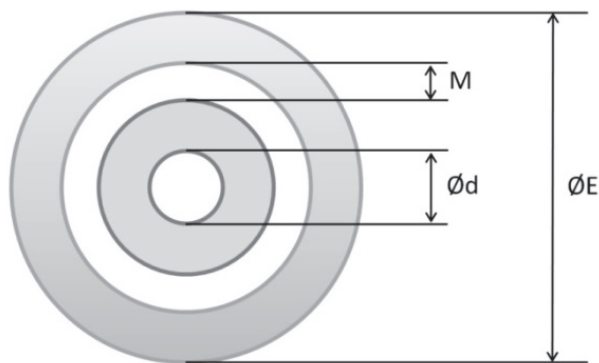

Figure 1. Dimensions of the measured electrodes.

Determination of electrical resistance of the ink

The measurement circuit scheme is shown in Fig. 2. It consists of a stabilized circuit, that supplies a voltage divider, wherein one resistor is constant and the other one, represented by the resistance of the conductive ink, is variable. The supply circuit is formed by LM317 voltage stabilizer, which enables setting of the supply voltage to 2 V and its fine adjustment. The value of the supply voltage has been chosen so that only a small current flows through the circuit. This prevents excessive heating of the conductive ink. Electrical resistance of the constant resistor in the divider is 10 kΩ, to ensure a constant current in the divider circuit. The electrical resistance of the ink was calculated using the formula (1):

$$R_{INK} = \frac{R_{CONST} \cdot U_{INK}}{U_{NAP} - U_{INK}} \quad (1)$$

where: R_{INK} – electrical resistance of the ink; R_{CONST} – constant electrical resistance 10 kΩ; U_{INK} – measured voltage; U_{NAP} – stabilized voltage – power supply for sensors.

The measurement of the voltage on the conductive ink – needed to calculate the resistance values in the divider – was performed by the DAQ device NI 6008. The measured voltage U_{INK} from the sensor was connected to an analog input of the DAQ card and it was measured by RSE method (Reference Single Ended) against ground potential. Voltage U_{NAP} from the stabilizer supplies the voltage divider R_{konst} and R_{ink} attached to DAQ card, where R_{ink} means the measured resistivity of the sensor. The output of the DAQ card was connected to a PC via USB. The entire measuring station was controlled by the NI LabView program. A LabView application was also created, which enables the recording and the calculation of the electrical resistance of the conductive ink.

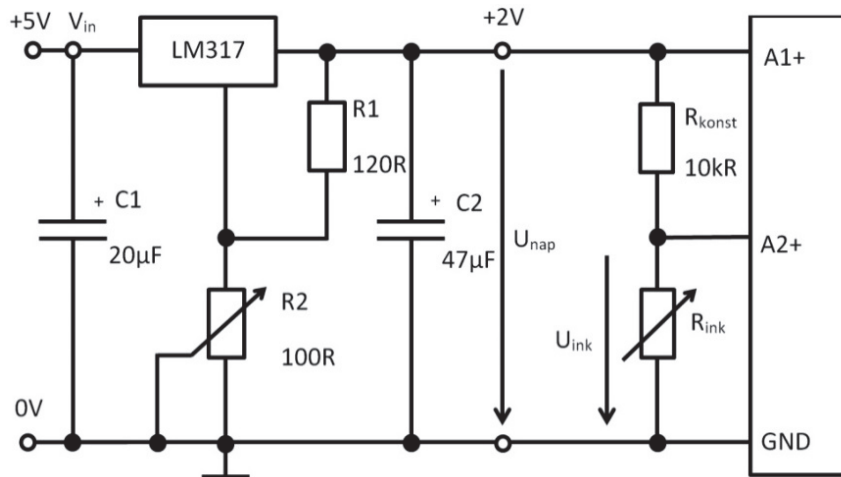

Figure 2. Circuit scheme for measuring of the resistance of the conductive ink.

Measurement method

Measurements of the properties of conductive ink were performed at a robotized workplace equipped with a Turbo Scara SR60 robot. The basic step of vertical motion of the robot's arm is 0.025 mm with a 0.01 mm resolution. The resolution caused some problems while setting the force value during the measurements of the hysteresis, as it was not possible to set exactly the same force as while loading. The pressure was imposed by means of the vertical motion of the robot's arm. A Hottinger DF2S-3 tensometer force sensor with a measuring tip with a \varnothing 3 mm circular surface was fixed to the end of the robot's arm. This force sensor was chosen because of its high sensitivity and appropriate range. The accuracy of the force sensor is 0.03%, its maximum permissible load is 200 N and its nonlinearity is 0.03%. The sensor is calibrated in the way that 1 gram corresponds to an output voltage change of 1 μ V. The control unit is set up to display the values in grams; the conversion into the pressure values was made subsequently. The pressure imposed on the electrodes was calculated from the known area of the surface of the measuring tip and the exerted force. This resulted in the measured range of pressure values ca. from 100 kPa up to 2,200 kPa for the particular measuring tip.

The foil with the deposited ink was placed on the electrode field. The measuring tip with its circular \varnothing 3 mm surface, which is larger than the diameter of the electrodes, touched down on the surface of one tactile point and pressed on the conductive ink deposited on the foil against the circular electrodes, via which the electric resistance of the conductive ink was measured. The pressure imposed on the electrodes was calculated from the known area of the surface of the measuring tip and the exerted force. The output voltage of the type DF2S-3 tensometer force sensor was measured by an Almemo 2890-9 Data Logger (Lufinka, 2014). In (Pavlovkin & Novák, 2012) is outlined the possibility of measuring of tactile sensors' frequency properties.

Fig. 3(a) shows the detailed view on the measuring head: (1) is for the conductive ink deposited on a foil, (2) indicates the measuring tip, (3) is the force sensor DF2S-3 and (4) indicates the robot's head. Fig. 3(b) presents the overall layout of the measuring post.

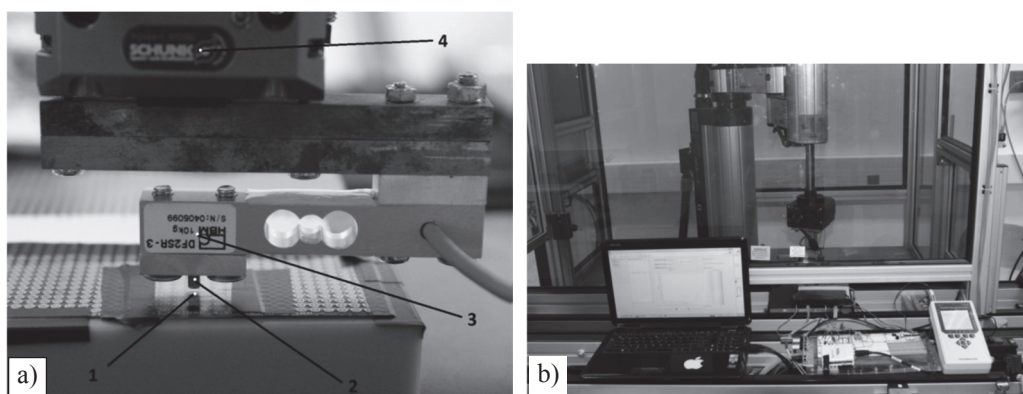

Figure 3. a) Detailed view on the measuring head, b) Layout of the robotized measuring post.

Loading and unloading procedures were performed to measure the hysteresis of the conductive ink. After each shift, the corresponding resistance and pressure values were logged by the NI LabView program. One measurement cycle thus contained 37 values. Between the individual measurement cycles, the electrodes were fully unloaded and there was a five-minute brake, so that the material could relax. The measurements were repeated 10 times for each ink layer thickness.

RESULTS AND DISCUSSION

The measured electrical resistance in dependence on applied pressure for PD-type electrodes for a particular ink layer of $7\ \mu\text{m}$ are represented graphically in Fig. 4. All measurements were repeated 10x and the total (combined) measurement uncertainty was calculated and graphically represented by respective intervals for each measured value. In the diagram both the loading cycle (triangle points) and the unloading cycle (round points) are depicted.

Hysteresis (i.e. a different shape of the curve in the loading and unloading cycle) is apparent, similarly as in the case when a conductive elastic material was used, however, it is much lower (Trinkl, 2011), which makes this transducer more suitable to measure the absolute pressure than elastic materials. Initial insensitivity is apparent in all electrodes, which is obviously caused by the force necessary for the touch-down of the foil with the deposited ink on the electrodes.

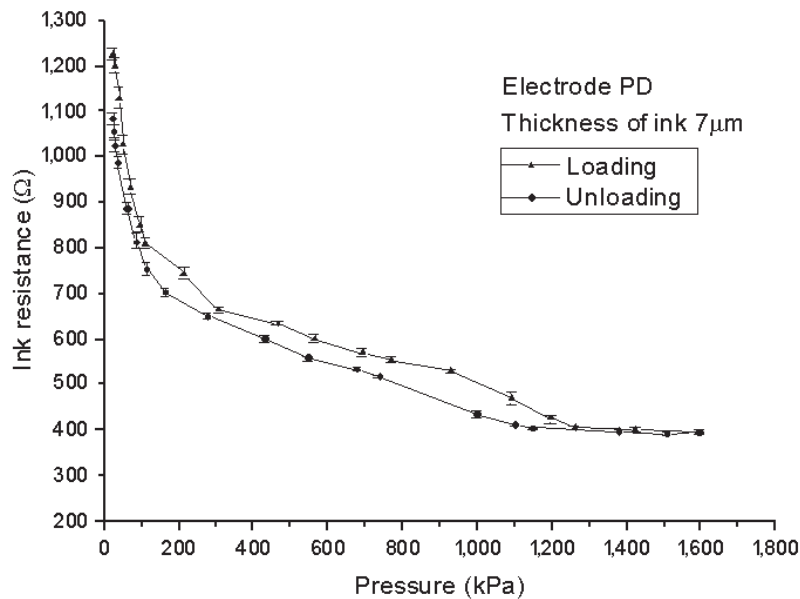

Figure 4. Dependence of resistance of a $7\ \mu\text{m}$ thick ink layer on the pressure for an PD-type electrode (loading and unloading).

Fig. 5 presents the comparison of the dependence of the variation of resistance on the pressure during loading of PD-type electrodes for various thicknesses of the deposited ink layer.

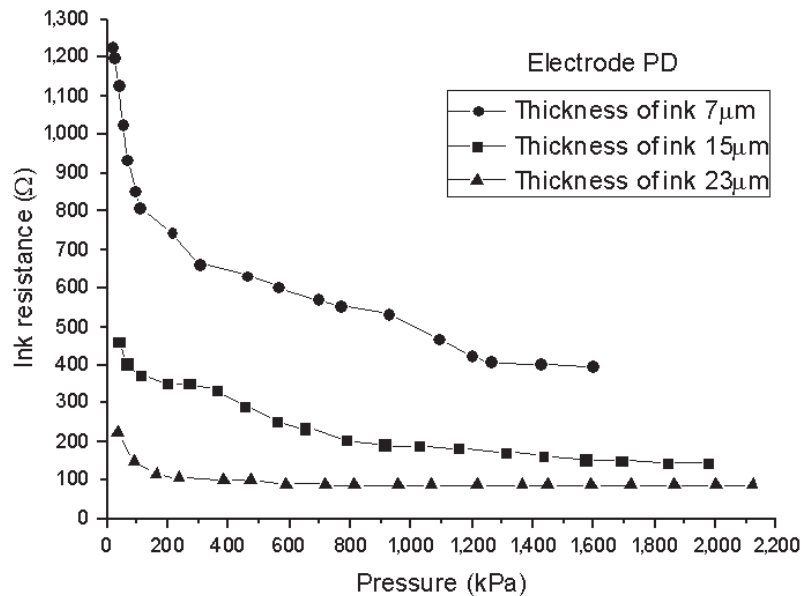

Figure 5. Comparison of PD-type electrodes with ink layers 7 μm, 15 μm and 23 μm.

From the diagram it is apparent that maximum sensitivity is achieved for a 7 μm thickness of the deposited ink; thicker ink layers exhibit only a small change in the ink’s resistivity for pressures of ca. 600 kPa and above and thus they are not suitable to measure higher pressure loads, as the resistivity changes only insignificantly which degrades the resolution of the transducer. The curve associated to the 7 μm ink layer is sufficiently smooth, with nearly linear dependency in the range from 300 kPa to 1,400 kPa.

Within a limited pressure range, the setup with a 7 μm ink layer and on a PD electrode was assessed as the best transducer within the experiment. Higher thicknesses increased the conductivity of the sensor and consequently decreased its resolution. All measurements showed some hysteresis caused predominantly by the inaccuracy of positioning of the robot and relaxation of the ink and foil.

CONCLUSIONS

Measurements proved that conductive ink could act as a force transducer converting force to electric resistance. Satisfactory results were obtained for DZT-3K conductive ink in a 7 μm layer; thicker ink layers degraded the resolution of the transducer.

However, during the measurements we found out some limitations of this type of conductive ink, namely limited resistance of the ink to mechanical stress and its little adherence to the surface of the electrodes. Since the tested ink is a water based one and

thus it exhibits little adherence to the electrodes, we had to select an alternative procedure by spraying the ink on the foil. To allow a direct application of the ink to the electrodes, it would be necessary to use another type of ink – a polymer based one. We will continue the measurements with these types of inks in the future.

ACKNOWLEDGEMENTS. The measurements were carried out within the IGA project of the Faculty of Engineering, Czech University of Life Sciences in Prague.

REFERENCES

- Lufinka, J. 2014. *Effect of Conductive Ink on Properties of Tactile Transducers*. Diploma thesis, CULS, Prague (in Czech).
- Pavlovkin, J. & Novák, D. 2012. Messung der Frequenzcharakteristiken von Passivfilter mittels des Systems rc2000. *Edukacja–Technika–Informatyka* **3**(2), 257–264.
- Souza, F.G., Michel, R.C. & Soares, B.G. 2005. A methodology for studying the dependence of electrical resistivity with pressure in conducting composites. *Polymer Testing*, **24**(8), 998–1004.
- Soares, B.G., Amorim, G.S., Souza, F.G., Oliveira, M.G. & Pereira da Silva, J.E. 2006. The in situ polymerization of aniline in nitrile rubber. In: *SYNTHETIC METALS*, **156**(2–4), 91–98.
- Trinkl, A. 2011. *Optimization of Design of Flat Tactile Transducers*. Dissertation, CULS, Prague, (in Czech).
- Volf, J., Trinkl, A., Novák, M., Bílek, J., Prikner, P. & Neuberger, P. 2012. Plantograf V12 with Optimal Size Determination Sensor Electrodes and its Using for Pressure Distribution Between Tire and Road. In: *XX World Congress IMEKO*. IMEKO, Busan. ISBN 978-89-950000-5-2 95400.
- Volf, J., Trinkl, A., Růžička, M. & Novák, M. 2009. Optimal Size Determination of Tactile Sensor Plantograf V08 and its Electrodes. In: *26th Symposium on Advances in Experimental Mechanics*, Leoben, Austria. ISBN: 978-3-902544-025.
- Volf, J., Vlček, J., Papežová, S. & Novák, P. 2006. Orthopaedic Investigation System For Medical Non-Invasive Diagnostics. In: *IMEKO – XVIII World Congress and IV. Brazilian Congress of Metrology*. IMEKO, Rio de Janeiro.