

Grain drying by use of changeable air flow method

G. Pupinis

Institute of Agricultural Engineering, Lithuanian University of Agriculture Raudondvaris,
LT-51132 Kaunas, Lithuania; e-mail: pupinis@mei.lt

Abstract. The article describes a new energy saving method for drying grain. The idea of the method is that once moisture released from grain decreases, air discharge going through the grain is reduced as well. 'Roland' variety of barley with 25% and 30% moisture content was used in the trial. It was dried with a changeable air discharge in order to maintain absorption qualities. After the drying process has begun, air flow to the grain is reduced in the process of drying as the relative moisture content of air passing through decreases. It has been established that the optimum initial air discharge is $800 \text{ m}^3 (\text{t h})^{-1}$. During grain drying air discharge is reduced and it can be described by equation $y = 969.85e^{-0.0114x}$, $R^2 = 0.8088$.

The scheme for a designed and manufactured trial device is presented. Intensity of air discharge and dynamics of moisture absorption in a layer of dried grain have been established.

Key words: Grain, air discharge, drying, dynamics of moisture absorption

INTRODUCTION

Currently the most popular grain preservation technique in our country is drying, which is the most energy-consuming operation in the technology of grain preparation (Toftdahl Olesen, 1987). Grain drying requires 2–2.5 times more energy than all grain production operations taken together (Striszak, 1980; Sidikov, 1987). The process requires the drying agent (air) to be heated and fans to rotate, resulting in high energy costs. Therefore, different techniques are being tested to reduce these costs: special changeable cross-sections for dryers have been manufactured (Novoshinskas & Zvicevichius, 2000) and anhydrous ammonia gas is being used (Hsieh et al., 1979).

Energy consumption to dry grain subject to the layer of grain blown through reaches 36.8–88.3 kWh t⁻¹ (Petrushevichius & Steponaitis, 1999).

Current recommendations for comparative discharge of drying grain by active ventilation is 400–500 m³ (t h)⁻¹ (Petrushevichius, 2003). When the drying process begins, grain moisture content is high and requires a large volume of air to be blown through the grain; farther along in the process of drying, as moisture content decreases, moisture release decreases and the process is no longer economical. Therefore, it is necessary to change the amount of air flowing through the grain in the process of drying in order to maximize moisture content in the air flow and to reduce energy consumption for fan rotation to the minimum. However, if the air velocity is too slow, the drying process will take too long and there will be a risk of grain spoilage.

Eimer's equation (1989) can be used to determine the length of time grain can be allowed to be stored without adversely affecting its quality, as follows:

$$T_{allow} = a \varphi^b e^{c\vartheta}, \quad (1)$$

where: t_{allow} – allowed grain-preserving duration;
 a, b, c , – constants, $a = 6$; $b = -12$; $c = -0.08$;
 φ – relative air moisture in grain layer;
 ϑ – grain temperature, °C.

When drying grain under production conditions and temperature and moisture content change, the conditions which have influence on grain spoilage process are changing rapidly. The influence of changing conditions was investigated by Maltry & Ziegler (1994). They present the following formula to calculate allowed storage time:

$$t_{allow} = \int_{Drying_{initial}}^{Drying_{finish}} \frac{dt}{a \cdot \varphi(t)^b \cdot e^{c \cdot \vartheta(t)} \cdot \left[d_1 \cdot (\vartheta(t) - d_2)^{d_3} \right]}, \quad (2)$$

where: d – constants; $d_1 = 0.0066$; $d_2 = 2.5$; $d_3 = 1.44$.

Presently the amount of air flow is not regulated in all equipment used for active ventilation. By doing so, it is possible to achieve a more efficient rate of air absorption qualities η and to reduce the power used by the fan's electric engine. The efficiency of electric power use can be relatively characterized by rate η :

$$\Delta = (\Delta d - \Delta d_o) / \Delta d, \quad (3)$$

where: $\Delta d, \Delta d_o$ - relative moisture absorption of incoming ambient air and outgoing air respectively is established according to Mollie diagram, $g \text{ kg}^{-1}$.

The higher the $\eta_{v.s.}$, the more efficient is the fan. When Δ values are not high, ambient air is not loaded with moisture and is used inefficiently. In order to optimize the drying process it is necessary to control only two parameters: relative moisture of incoming air (ϕ) and outgoing air from the material dried (ϕ_o). Their values are inversely proportional Δd and Δd_o . Energy saving modes are reached at $\phi_o - \phi > 15\%$ ($\eta_{v.s.} > 0.5$) in the first period of drying and at $\phi_o - \phi > 10\%$ ($\eta_{v.s.} > 0.35$) in the second period of drying. In the process of drying $\phi_o - \phi \rightarrow 0$, therefore, the energy saving rate in the second period of drying is decreasing and thus, in order to use electric energy efficiently, it is necessary to reduce the amount of air flow through the product. Thus, the velocity of air coming through the grain is reduced and the air contains more moisture. Electricity consumption in this drying method can be reduced by 30–40% (Avtomonov, 2000) compared with the traditional method using a constant air supply.

The research that supports changing air velocity when establishing the optimum modes for grain dryers has been carried out. The influence of air velocity in grain layers of different thickness, in establishing duration of drying, energy consumption and drying cost have been investigated. The trials included those in which the velocity

of passing air was changed from 0.15 to 0.96 m s⁻¹ and at three grain layers: 0.1; 0.2 and 0.3 m thick. The results presented are based on analysis of a 0.2 m thick layer (Table 1).

The data presented shows that when air velocity is 0.15–0.42 m s⁻¹ (grain layer height is 0.2 m), energy consumption doesn't change. The ratio of this air velocity range is inversely proportional to drying duration. Analogous results were obtained with different grain layer heights showed in Fig. 1.

Table 1. Duration of drying and energy consumption when drying feeding barley in 0,2 meter layer at velocity of airflow of 0.15 to 0.96 m s⁻¹ [9].

Air velocity, m s ⁻¹	0.15	0.23	0.32	0.42	0.5	0.57	0.68	0.96
Drying duration, h	0.57	0.36	0.26	0.20	0.18	0.16	0.14	0.10
Energy consumption,, kJ kg ⁻¹	4400	4250	4250	4280	4560	4724	4880	4900

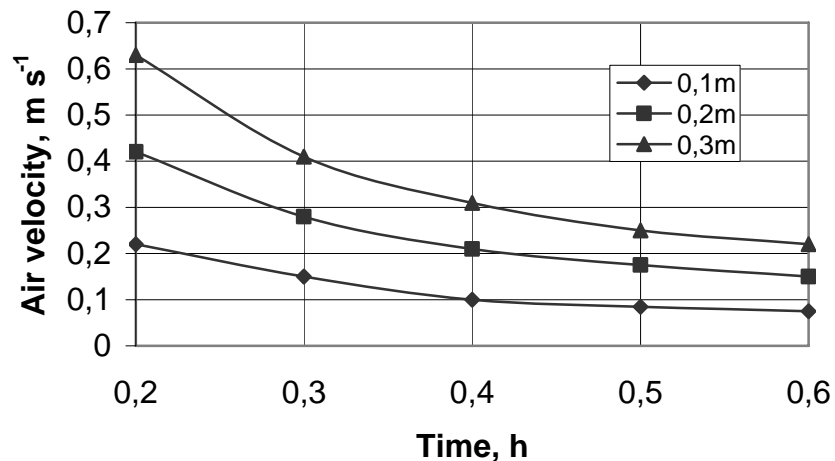

Fig 1. Dependencies of air velocity on drying duration at different grain layer heights.

The height of grain layer and drying agent velocity are directly related to the most important drying parameter: duration of drying agent present in grain and its moisture content. The optimum velocity of the drying agent is achieved when it absorbs

moisture and 100% moisture is achieved on the very surface of the bin releasing the grain. If the air is blown through the grain too fast, it is not fully loaded with moisture. When the velocity is too slow, it reaches 100% moisture while in the middle of the bin and, while passing through the other layers of the bin, it not only fails to absorb moisture but in some cases carries moisture to the upper layers of the bin. Therefore, the drying agent velocity at different times in the drying process has to be adequate: if the air velocity is too fast, the grain can be taken from the dryer or the drying agent leaves the dryer without being loaded with moisture. Both cases represent inefficient ways of drying. Drying of agricultural products by changing the air flow amount has not been widely investigated. (Articles by Sidikov, 1987 and Avtomonov, 2000 are among the few describing this stage of the process.)

MATERIALS AND METHODS

The trials were conducted in the Institute of Agricultural Engineering, Lithuanian University of Agriculture using a special laboratory dryer designed to study grain drying. The equipment used in the drying process research using changing air flow velocity is shown in Fig. 2.

Two fans blow air into the dryer. The first fan C-4-70 No2.5, pressure capacity, 700 Pa and throughput – $2000 \text{ m}^3 \text{ h}^{-1}$, is switched on in order to force major air flow through the dryer, i.e., over $500 \text{ m}^3 \text{ h}^{-1}$ or air. The air flow is regulated by bolts. The second fan is rotated by a 27 V direct current motor. The amount of air flow is regulated by changing the frequency of motor rotation and by bolts. This fan is switched on at low air flow, i.e., lower than $500 \text{ m}^3 \text{ h}^{-1}$. Two gas counters are used with these fans: RG-40-1, $L_{\min.} = 4 \text{ m}^3 \text{ h}^{-1}$, $L_{\max.} = 40 \text{ m}^3 \text{ h}^{-1}$ and G6 $L_{\min.} = 0.06 \text{ m}^3 \text{ h}^{-1}$, $L_{\max.} = 10 \text{ m}^3 \text{ h}^{-1}$, respectively.

Static air pressure is measured by a micro manometer MKB-250, precision class – 0.02 applying Pito tube. The dryer is made of 8-mm thick plywood. In order to reduce heat lost through the dryer's walls they are covered with 50 mm thick foam rubber which, in turn, is covered with metal foil to partially reflect heat and to prevent mass heat exchange. The front part of the dryer has a small door used for inserting and removing containers which are also covered with foam and metal foil. There are 10 containers, with a total height of 100 mm. Thus, the process of drying 1 m thick grain layer can be analysed. When analysing the grain layer of variable height, the containers are removed at the same time, leaving the necessary number of containers in place to maintain the grain layer at required height.

There are gaps between containers to insert air temperature and relative moisture transducers FH646-1, air temperature and relative moisture recorders ALMEMO 5590-2, computer PENTIUM 166 and electronic scales METLER S B. Power P_t used by the fan has been calculated using this formula:

$$P_t = P / \eta_{\text{fan}} \cdot \eta_{\text{el mot}}, \quad (4)$$

where:

P_t – power used by fans, W;

P – power required to blow air through grain, W;

η_{fan} – rate of efficiency of fan;

$\eta_{\text{el mot}}$ – rate of efficiency of electric motor.

$$P = L \cdot p, \quad (5)$$

where:

air flow discharge, m^3s^{-1} ,
 p – air pressure, Pa.

Barley variety 'Roland' was used in the trials; moisture content, $W = 25\text{--}30\%$. The moisture was established in (IELUA) chemistry laboratory using standard methods. The dryer was loaded with 16 kg of barley which was poured into the containers in a 10-cm thick layer. Each container with grain was weighed and put into the dryer. Container mass indicators were recorded in the log. After the containers had been filled, the door was closed and the recorder of air temperature and relative moisture and the fan were switched on. The recorder registered air temperature and relative moisture every 0.5 hour.

The dryer was installed on the premises of the Institute laboratory; therefore, the parameters of the air flow were comparatively stable. The temperature of the air flow varied from 14 to 17°C and the moisture content varied from 45–65%. During the trial the moisture of the outgoing air is monitored. When the outgoing air moisture decreased to 85%, the amount of air flow was reduced. The containers were weighed every 4 hours or when the parameters of air flow were changed. When the process stabilized, the containers were weighed every 12 hours. At the moment of weighing the fan was switched off. The door was opened, the container taken out, weighed, its mass recorded in the log and it was put back in the dryer, the door shut. All containers were weighed in the same manner. The weighing time, air pressure and indicators of air counter were recorded. The fan was switched on. The trial was completed when the grain reached conditioned moisture. The trial was made by blowing an initial air amount of $2000 \text{ m}^3 (\text{t h})^{-1}$, $1000 \text{ m}^3 (\text{t h})^{-1}$ and $500 \text{ m}^3 (\text{t h})^{-1}$ through grain. Comparative trials were also carried out at a fixed velocity of air flow in order to establish energy consumption required to dry grain.

RESULTS AND DISCUSSION

In analysing the new grain drying technology in which comparative air flow is about $L = 2000 \text{ m}^3 (\text{t h})^{-1}$, we looked into two of the most typical trials. The first trial was performed while drying the grain of moisture content $W = 29.8\%$ with initial comparative air discharge $L_{\text{initial}} = 2375 \text{ m}^3 (\text{t h})^{-1}$ and reducing it in the process of drying until the relative moisture of the outgoing air became less than 85%. The other trial – when grain moisture $W = 27.5\%$ and the average air discharge $L_{\text{average}} = 2017 \text{ m}^3 (\text{t h})^{-1}$ - attempted to keep the air discharge stable at about $L = 2000 \text{ m}^3 (\text{t h})^{-1}$ during the entire trial. The drying was more intensive when the air discharge was stable. Variations of comparative air discharge blown into the dryer during both trials are shown in Fig. 3.

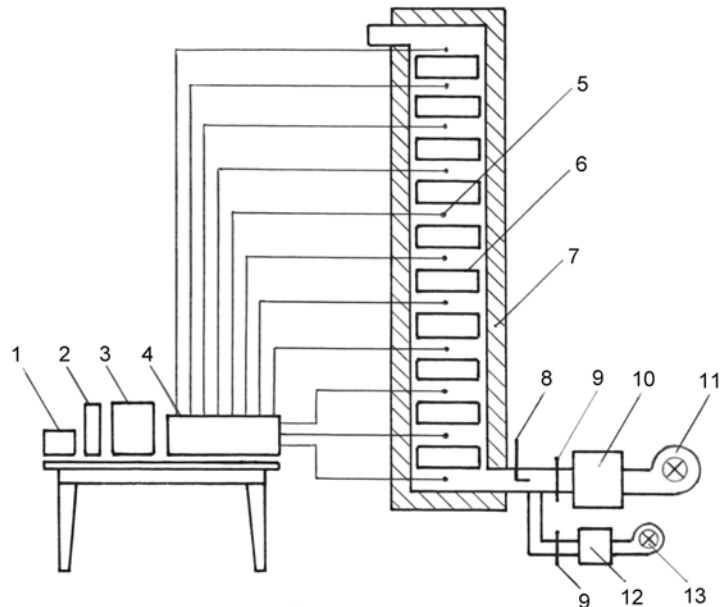

Fig. 2. Stand scheme of grain drying by changeable air flow. 1-scales METLER S B; 2- micro manometer MKB-250; 3-computer PENTIUM 166; 4-recording device ALMEMO 5590-2; 5- transducers FH646-1; 6-dried grain; 7-dryer; 8-Pito tube; 9-air regulating bolts; 10-gas counter RG-40; 11-fan C-4-70; 12- gas counter G6; 13- fan.

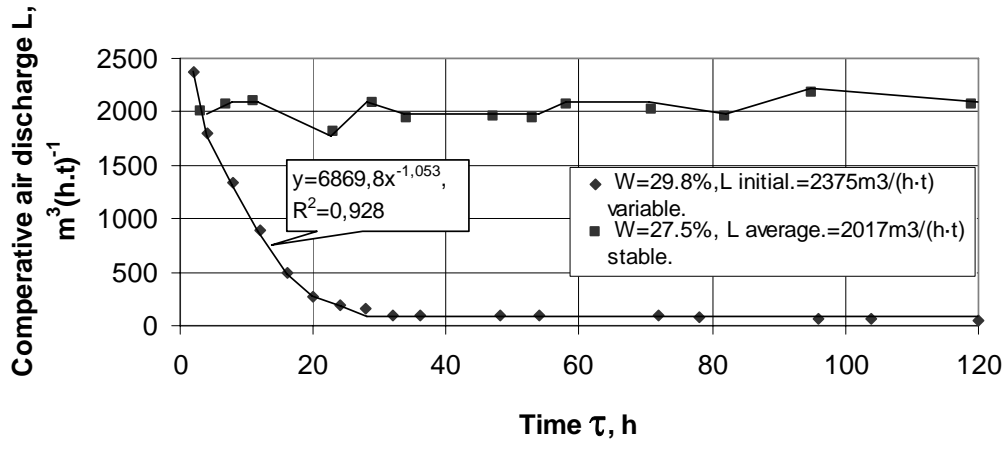

Fig. 3. Variation of air discharge blown into dryers when drying barley of 'Roland' variety with moisture content $W = 29.8\%$ and air discharge blown $L_{initial} = 2375 \text{ m}^3 (\text{t h})^{-1}$. It was reduced during drying. Barley, moisture $W = 27.5\%$, air discharge blown $L_{average} = 2017 \text{ m}^3 (\text{t h})^{-1}$, which was stable during drying process.

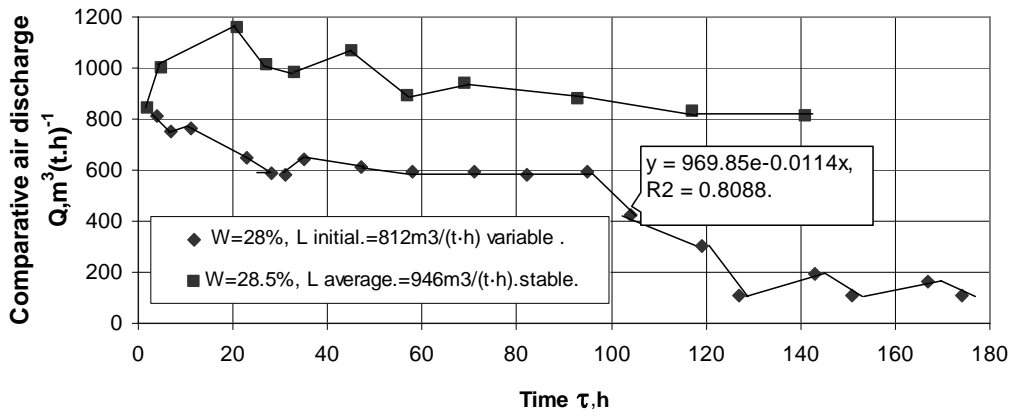

Fig. 4. Variation of air discharge blown into dryers when drying barley of 'Roland' variety with moisture content of $W = 28\%$ and initial comparative air discharge is $L_{initial} = 812 m^3 (t h)^{-1}$. It was reduced during drying. Barley, moisture content $W = 27.5\%$, comparative air discharge $L_{average} = 946 m^3 (t h)^{-1}$, which was stable during drying process.

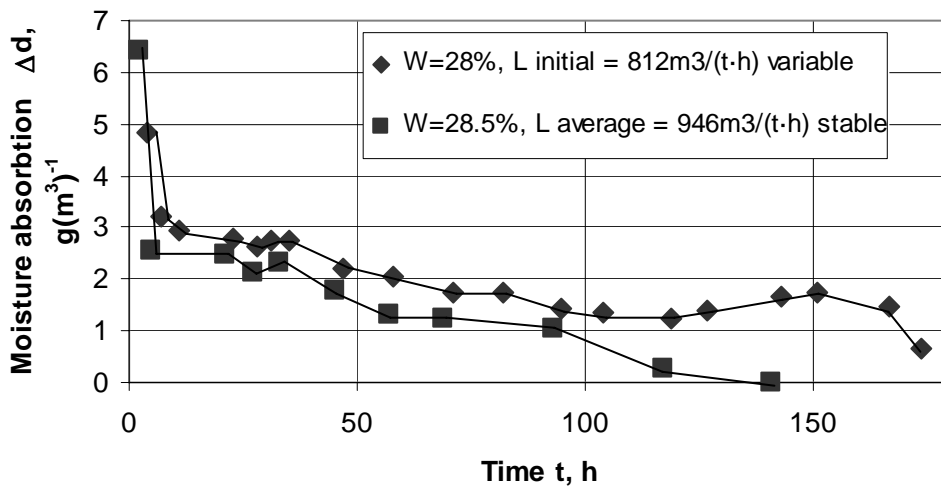

Fig. 5. Variation of moisture absorption when drying barley of 'Roland' variety moisture content $W = 28\%$ and initial comparative air discharge is $L_{initial} = 812 m^3 (t h)^{-1}$. It was reduced during drying. Barley, moisture content $W = 28.5\%$, comparative air discharge $L_{average} = 946 m^3 (t h)^{-1}$, which was stable during drying process.

In the first case, air discharge during drying was reduced after reaching an outgoing air discharge of 85%. Air discharge had to be reduced during the first 20 hours of drying. The decrease of comparative air discharge can be best described by equation $y = 6869.8x^{-1.053}$, $R^2 = 0.928$. After that the grain was gradually drying and the comparative discharge of air was about $100 \text{ m}^3 (\text{t h})^{-1}$. After 60 drying hours relative air moisture started to decrease and at the end of the trial it was 70%. In the second case, in the beginning of the trial the outgoing air moisture was 95% but after 10 hours it started to decrease; after 30 hours it dropped down to 60% and gradually decreased..

As we can see, in the first case the air leaving the dryer was of higher relative moisture, whereas in the second trial air absorptive features were not fully used. When air discharge was changed, moisture absorption in the beginning of the trial was up to 3.5 g m^{-3} of air and in the process of the trial it decreased to 1 g m^{-3} . Meanwhile, drying moisture absorption in the trial with constant air discharge reached 1 g m^{-3} after 30 hours of drying and it gradually decreased. Thus, air absorptive features were not used and the drying process was inefficient. Other trials were carried out while drying the same variety of grain. The air discharge of $1000 \text{ m}^3 (\text{t h})^{-1}$ was blown through. In the first trial comparative air discharge was gradually reduced and in the second one it was kept stable. The grain was more intensely dried in the dryer where air flow was stable. Drying was complete in the dryer with stable air flow after 140 hours, whereas, drying with variable air flow took 180 hours. The discharges of air blown through the dryer are shown in Fig. 4.

As it can be seen, average air flow was about $946 \text{ m}^3 (\text{t h})^{-1}$ in the trial with stable air discharge. When drying with variable air discharge more intense drying was achieved during the first 10 hours. Later the process stabilized and after 90 hours the outgoing air moisture dropped down to 80%. The drying entered the final phase. The decrease of comparative air discharge is best described by equation $y = 969.85e^{-0.0114x}$, $R^2 = 0.8088$. The first, intensive stage of drying can be explained by rapidly evaporating surface moisture. When drying grain with stable $946 \text{ m}^3 (\text{t h})^{-1}$ air discharge, as in the case with variable discharge, moisture absorption in the beginning of the trial was $5.0\text{--}6.5 \text{ g m}^{-3}$, decreased to $2.5\text{--}3.0 \text{ g m}^{-3}$ during first 10 hours and gradually decreased in the process of the trial (Fig. 5).

When the air discharge was stable only in the initial drying stage, moisture absorption was higher than that in the trial with variable air discharge. That leads to the conclusion that reducing air discharge facilitated better use of air absorptive features. Drying with stable air discharge resulted in grain drying for 140 hours; drying with variable air discharge continued for 180 hours. Nevertheless, this drying duration was not higher than the limitary duration of mould formation.

Other trials were carried out when drying the same variety of grain and blowing about $500 \text{ m}^3 (\text{t h})^{-1}$ of comparative air discharge through it. When the air flow was variable, the initial comparative air discharge was $L_{\text{initial}} = 500 \text{ m}^3 (\text{t h})^{-1}$ and grain moisture was $W = 27.5\%$. When the stable comparative air discharge was $L_{\text{average}} = 514 \text{ m}^3 (\text{t h})^{-1}$, the trial was carried out with the grain of $W = 27.9\%$ moisture. The drying progress in the beginning of the trial was similar and the grain in both dryers was drying at a similar rate. Discrepancy of mass variation curves was about 5% and it can be explained by uneven air discharge, variations of air temperature and moisture. In the beginning of the trial the air discharge blown into both dryers was similar (Fig. 6).

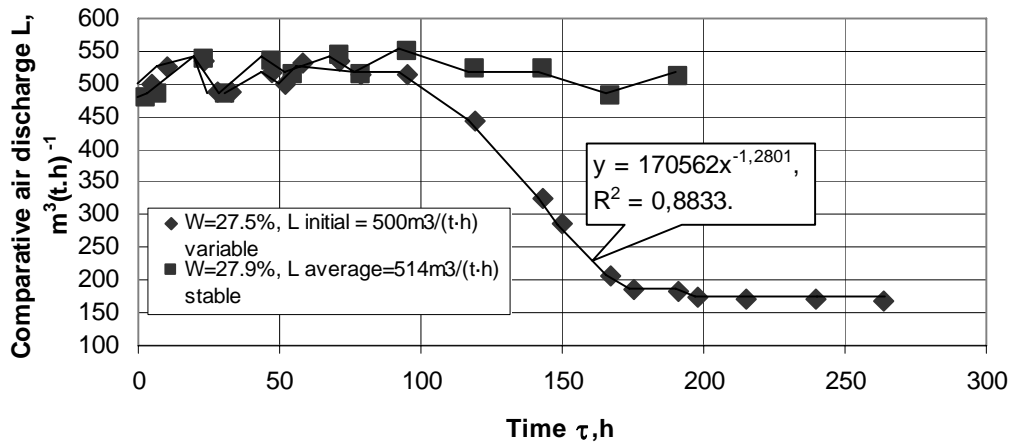

Fig. 6. Variation of air flow when drying barley of 'Roland' variety moisture of which $W = 27.5\%$ and initial comparative air discharge is $L_{\text{initial}} = 500 \text{ m}^3 (\text{t h})^{-1}$. It was reduced during drying. Barley, moisture of which $W = 27.5\%$, comparative air discharge $L_{\text{average}} = 514 \text{ m}^3 (\text{t h})^{-1}$, which was stable during drying process.

After 100 drying hours the moisture content of air leaving both dryers started to decrease, therefore the air flow in the dryer with variable discharge was reduced. After 100 hours of drying, the comparative air discharge was reduced. The extent of reduction is best described by equation $y = 170562x^{-1.2801}$, $R^2 = 0.8833$. Therefore, the moisture of the outgoing air remained about 80% up to 150 hours after which it gradually started to decrease, whereas, in the dryer with stable air discharge, moisture content started to decrease after 95 hours of drying; after 180 hours it dropped to 60%. The moisture of the outgoing air from the dryer with variable air discharge decreased gradually: after 264 hours of drying it reached the minimum value and the trial was finished. In the beginning of both trials moisture absorption was rather high and reached 6.2 g m^{-3} and 8.1 g m^{-3} . More intense drying was observed in the dryer with variable air discharge. Moisture absorption increased by 5%. After 95 hours, moisture absorption in the dryer with stable air discharge decreased, whereas it remained the same in the dryer with variable air discharge and did not start to decrease until after 150 hours.

When the grain was dried by a stable comparative air discharge $L_{\text{average}} = 2017 \text{ m}^3 (\text{t h})^{-1}$, 3842 m^3 of air were blown through the dried grain. Meanwhile, in the second case, when variable air discharge was $L_{\text{initial}} = 2375 \text{ m}^3 (\text{t h})^{-1}$, 1987 m^3 of air were blown. The amount of energy used to blow these air discharges differed by nearly 5 times, i.e., in the first case the required energy amount was 1042 W h; in the second case, it was 409 W h. That can be explained by the fact that the higher velocity of air flow through grain, the more the energy consumption increases. The power required to blow 1 m^3 of air during the first trial was 8.7W; during the second trial it was 3.4W.

Other trials which were carried out when drying the grain at comparative air discharge of about $L = 1000 \text{ m}^3 (\text{t h})^{-1}$ resulted in the following: to dry 16 kg of grain at stable comparative air discharge of $L_{\text{average}} = 946 \text{ m}^3 (\text{t h})^{-1}$, 2086 m^3 air flow was required, whereas at variable comparative air discharge $L_{\text{initial}} = 812 \text{ m}^3 (\text{t h})^{-1}$ only 1349 m^3 of air was needed. Therefore, energy consumption to blow each amount of air was 417.4 W h and 133.4 W h respectively and the power required to blow one cubic meter of air was 2.9 W and 0.7 W respectively.

Trials which were carried out when drying the grain at comparative air discharge at stable $L_{\text{average}} = 514 \text{ m}^3 (\text{t h})^{-1}$, 1480 m^3 of air was blown; at variable $L_{\text{initial}} = 500 \text{ m}^3 (\text{t h})^{-1} - 1051 \text{ m}^3$ of air was blown. Therefore, the energy used to blow this air through was 221.9 W h and 115.8 W h respectively. Working power to blow 1 m^3 of air was 1.2 W and 0.4 W respectively. Energy consumption to dry 1000 kg of 'Roland' variety barley when using various air discharges is shown in Fig. 7.

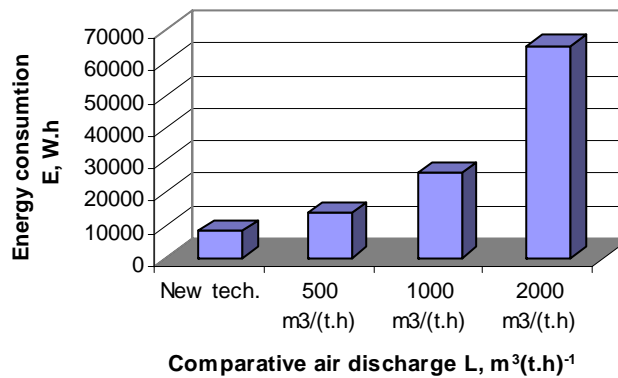

Fig. 7. Energy consumption to dry one ton of “Roland” variety barley.

When drying at stable $L_{\text{initial}} = 500 \text{ m}^3 (\text{t h})^{-1}$ air discharge, it took about 180 hours for the grain to dry, whereas drying with variable air discharge continued up to 264 hours. However, this lengthy duration put the grain at risk of moulding. Therefore, we can recommend that the optimum initial comparative air discharge is $800 \text{ m}^3 (\text{t h})^{-1}$ and drying duration is 24 hours. After 24 hours of drying the comparative air discharge should be reduced to $600 \text{ m}^3 (\text{t h})^{-1}$ and drying continued for another 70 hours. After that, the comparative air discharge should be reduced to $150\text{--}180 \text{ m}^3 (\text{t h})^{-1}$ to finish drying the grain.

CONCLUSIONS

1. 'Roland' variety of barley was dried by stable air discharge $L_{\text{initial}} = 812 \text{ m}^3 (\text{t h})^{-1}$ for 180 hours. This drying duration was not longer than the liminary duration of mould formation. Therefore, this air discharge can be regarded as the optimum in drying 'Roland' variety of barley of $W = 25\text{--}29\%$ moisture.

2. To dry 'Roland' variety of barley of $W=25-29\%$ moisture content $8337.5 \text{ W h t}^{-1}$ of energy is needed to blow air.

3. We can recommend that the optimum initial comparative air discharge is $800 \text{ m}^3 (\text{t h})^{-1}$ and drying duration is 24 hours. After 24 hours, the comparative air discharge should be reduced to $600 \text{ m}^3 (\text{t h})^{-1}$ and the drying process continued for another 70 hours. After that, comparative air discharge should be reduced to $150-180 \text{ m}^3 (\text{t h})^{-1}$ to finish drying the grain.

REFERENCES

- Avtomonov, I. J. 2000. Technology improvement for hay drying by active ventilation. *Mechanization end rural electrification* **1**, 10–13 (in Russian).
- Sidikov, A. 1987. Results investigated barley drying process in thick layer. *Research - Technical Bulletin. All Russian research Institute mechanization agricultural*. No. 67 (in Russian).
- Eimer, M. 1989. Konservierung und Lagerung von Getreide mit gesicherter Qualität // Power Processing and Systems. *Proceedings of the 11th Int. Congress of Agric. Eng.*, Dublin, 4-8 Sept. / Bd. 4: A. A. Balkema; Rotterdam Brookfield, 1989. s. 2267–2273.
- Hsieh, R.C., Bakker-Arkema F.W., Cuppet S.L. & Brook R.C. Ammonia assisted grain drying in fixed-bed systems// *Trans. ASAE Paper Nr. 79-3075*.
- Maltry, W. & Ziegler, Th. 1994. Simulation der instationären Trocknung von Saatgutschüttungen unter Nutzung von Sonnenenergie. *Bornimer Agrartechnische Berichte Heft 5*, Potsdam-Bornim S. 105–117.
- Novoshinskas, H. & Zvicevichius, E. 2000. Grain drying in variable cross – section tank. *Agricultural engineering research paper* **32**(3), 61–68 (in Lithuanian).
- Petrushevichius, V. 2003. The comparative discharge of blowing through grain air while drying by active ventilation. *Agricultural engineering research papers* **35**(4), 22–29 (in Lithuanian).
- Petrushevichius, V. & Steponaitis, V. 1999. Requirement energy for grain drying by active ventilation. *Agricultural engineering research papers* **31**(2), 19–30 (in Lithuanian).
- Striszak, S.V. 1990. Reserve energy requirement for grain drying by active ventilation in grain silage. *Intensifications rural productions in collective farms. Cheliabinsk institute mechanization and rural elektrifikacion. Cheliabinsk*, 22–26 pp (in Russian).
- Toftdahl Olesen H. Grain drying. *Innovation Development engineering ApS*, 1987.