

The cleaning of caucasian goat's rue chaff in the combine harvester cleaner

E. Vaiciukevičius, A. Sakalauskas, E. Šarauskis, R. Domeika and V. Butkus

Department of Agricultural Machinery, Lithuanian University of Agriculture,
Studentu Str. 15A, LT-53361 Kaunas r., Lithuania; e-mail: ZUM.katedra@lzuu.lt

Abstract. Caucasian goat's rue (*Galega orientalis* L.) is perennial grass which can be harvested as green mass and as seeds. The expansion of grasses with small seeds, such as Caucasian goat's rue has been stopped because of unsolved problems of yield processing and seed preparation in Lithuania.

Caucasian goat's rue grass is usually harvested in the second half of July when the grass stems are still green and comprise about 43%. The pods of Caucasian goat's rue grass are in the top part of the plant. When the weather is windy the small amount of the pods are broken off the stem. The pod does not open by itself. Therefore, it is very important to duly adjust the threshing apparatus of the combine harvester to thresh all the seeds from the pods. The seed cleaning from the moist chaff of the green mass in the cleaner of the combine harvester is rather problematic because of significant seed losses.

The agro-engineering of Caucasian goat's rue grasses has been investigated since 1985. The yield harvesting losses exceed the permissible limit by 2–3 times. The greatest seed losses during the harvesting occur in the cleaner of the combine harvester. Thus the cleaning of the chaff of Caucasian goat's rue plants is a topical and acute issue that needs thorough investigation. The main research object is the separation of Caucasian goat's rue grasses through the upper sieve of the combine harvester cleaner: our paper describes our test results, which largely depend on the cleaner load, the oblique air flow rate in cascades, and the gaps between the upper sieve openings.

Tests show that $1.5 \text{ kg} \cdot (\text{s} \cdot \text{m})^{-1}$ of Caucasian goat's rue chaff can be fed into a combine harvester cleaner. At the air flow rate of $5 \text{ m} \cdot \text{s}^{-1}$ approximately 62.2% of the seeds are separated through the upper sieve in openings at the beginning of the upper sieve, resulting in seed separation losses of about 5%. When Caucasian goat's rue chaff is cleaned, 6 mm gaps should be left in upper sieve openings.

Key words: Caucasian goat's rue, combine harvester cleaner, upper sieve, chaff, separation, seed cleaning losses

INTRODUCTION

Caucasian goat's rue (*Galega orientalis* L.) is perennial grass which currently occupies 1500 ha area in Lithuania and will be increased in the immediate future. One of the main reasons for the expansion is the increasing use of fields for biofuel production, green mass, and production of grass flour, silage, hay, and haylage (Čaikauskas, 1995). For the production of green mass Caucasian goat's rue grasses are harvested 2–3 times during summer. Depending on the meteorological situation the

yield of the green mass is about 40–50 t·ha⁻¹, and that of hay is 9–10 t·ha⁻¹. The seed yield is 0.3–0.7 t·ha⁻¹ (Sprogis, 1992; Čaikauskas, 1995).

Power grasses producing biomass used for the generation of bio-energy have been investigated at the Lithuanian Agricultural Institute since 1997 (Jasinskas, 2006). Caucasian goat's rue grasses produce large quantities of mass even during unfavourable meteorological conditions. Test results disclosed that the mixture of Caucasian goat's rue grasses with other grasses, such as *Agrimonia*, *Melilotus* is the best for fabrication of biofuel.

The problems of seed harvesting of Caucasian goat's rue grasses have not been fully solved. When crop combine harvesters are used for the seed separation of Caucasian goat's rue grasses, the total seed losses exceed the permissible ones by 2-3 times (Vaiciukevičius, 1999), because wet stems with abundant green leaves are fed into the combine harvester. The threshing drum crumbles stems and leaves thus the combine harvester cleaner becomes extremely loaded (Vaiciukevičius, 2002), and the small seeds remain trapped in the thick and viscous chaff layer conveyed through the sieve surface.

When the weather is good Caucasian goat's rue grasses can be swathed. Thus the moisture content of seeds and stems is reduced and the seeds in the pods become mature (Špokas, 2003). The seed losses of Caucasian goat's rue grasses in swathes are usually 2 times less than when harvested directly with combine harvester. In order to minimize the moisture of Caucasian goat's rue grasses during harvesting they can be desiccated. Tests showed that desiccation had no impact on the seed moisture content, but the leaves became dry and some fell on the soil surface, thus the total moisture content of the plants decreased by 10%.

The cleaner should be redesigned in order to minimize seed losses during separation. M.G. Stepichev (1975) noticed that the cleaner throughput was less than that of the threshing apparatuses thus in redesigning the threshing apparatus and the straw walkers the efficiency of the cleaner should be increased and the influence of its inclination direction and its angle to the quantitative indices of the operation should be reduced (Kutzbach, 1981; Grobler 1993).

Dahany (1993) noted that the air flow rate at the end of the conventional cleaner was greater than at the beginning. Therefore, the chaff layer at the beginning of the sieve was fluffed insufficiently and the grains were thrown from the sieve end. He made the test bench where the air flow rate could be changed via the length of the upper sieve. The separation of the wheat chaff with trapped 70% of grains and 30% of straw chaff of 20 mm length were tested. It was concluded that when the air flow rate through the whole length of the upper sieve was constant (2.5 m·s⁻¹), the permissible grain losses were exceeded when the chaff was fed at the rate of 3 kg·(s·m)⁻¹ onto the upper sieve. A.G. Ribalko (1989) and J. Račys (1987) stated that grass harvesting was far too complicated compared with crop harvesting: 40–50% of mature seeds were lost in the field during yield harvest (Strakšas, 1992). The chaff moisture content and coherence had significant impact on the seed cleaning losses (17–20%). The conventionally designed cleaner was not sufficiently efficient to separate all the seeds. Ribalko suggested installing the active separator instead of the wire grate bars at the end of the straw walkers to intensify the seed separation from the chaff.

The cascade-type cleaner without sieves was designed in the Rostov Agricultural Engineering Institute to clean the chaff with a greater amount of the crushed straw

(Alferov, 1970). The wire grate bars were arranged in cascades, and the chaff that fell from these cascades was further conveyed by the inclined air flows. Chaff and short straw pieces were the first to be separated through the wire grate bars.

The authors maintained that the number of the wire grate bars must match the permissible capacity of the cleaner. It was concluded that the cascade-type cleaner had 1.5–2 times higher performance than the conventional cleaner.

Kutzbach (1992) stated that practically all the manufacturers of the powerful combine harvesters had to install the two-cascade cleaner to increase productivity. Y. Chiao (2000) inferred that the second cascade activated the grain separation at the beginning of the upper sieve. It was especially important when the dense chaff layer was fed into the cleaner. The chaff layer was broken off in the second cascade, thus the released grain from the layer fell through the sieve.

During laboratory and field tests A. Srivastava (1990) defined that the combine cleaner was about 3 times more sensitive to the change of plant characteristics than the straw walkers. H. D. Kutzbach (1991) noticed that variation of chaff properties during harvesting significantly influence the cleaning performance.

Most of the authors tested combine harvesters efficiency while cleaning the crop chaff, and there were few references to investigations when the chaff of small-grain plants or grasses was cleaned. For this reason, the problems related to the reduction of the seed cleaning losses from the chaff of Caucasian goat's rue grasses are acute.

MATERIALS AND METHODS

The seed cleaning of Caucasian goat's rue grasses in the cascade type cleaner has not been fully investigated in Lithuania. The chaff separation through the upper sieve openings is being investigated for the first time. The research object is the chaff separation of Caucasian goat's rue grasses through the upper sieve of the combine harvester cleaner. The research goal is to test the chaff separation of Caucasian goat's rue grasses through the upper sieve openings by changing the cleaner load, the rate of the oblique air flow in the cascades, and the gaps between the openings of the upper sieve in order to reduce the seed cleaning losses to the permissible limit.

The chaff of Caucasian goat's rue grasses was used for the tests. Desiccated goat's rue grasses were harvested on the 25th of August. The average seed moisture content was $W_1 = 8.7\%$, and that of the chaff was $W_2 = 22.7\%$.

The tests were fulfilled with the two-cascade combine harvester cleaner bench (Fig.1). The test bench consists of the frame 15, conveyor 1, straw walker 2, wire grate bars 5, short sieve 6, upper sieve 8, boxes 7 and 11, box 10, ventilator 14, and drive 3.

The chaff was fed onto the band conveyor 1 of 0.5 m width and 5.8 m length. The chaff separated through the short sieve 6 and the upper sieve 8 with openings was collected into the boxes installed under the sieves. The chaff separated through the short sieve was collected into box 7, and the chaff separated through the upper sieve was collected into box 11. The straw together with unseparated seeds was collected in box 10. The chaff of every box was weighed. Seeds were separated from chaff and straw, weighed and seed separation, seed cleaning losses, and cleanliness percentage were calculated. Chaff and seeds were weighed with scales SK 5001: the accuracy was ± 1 g. The air flow rate in the cascades was measured with OMEGAFLO HH 600. The gaps of the upper sieve openings were measured with standard measuring meter.

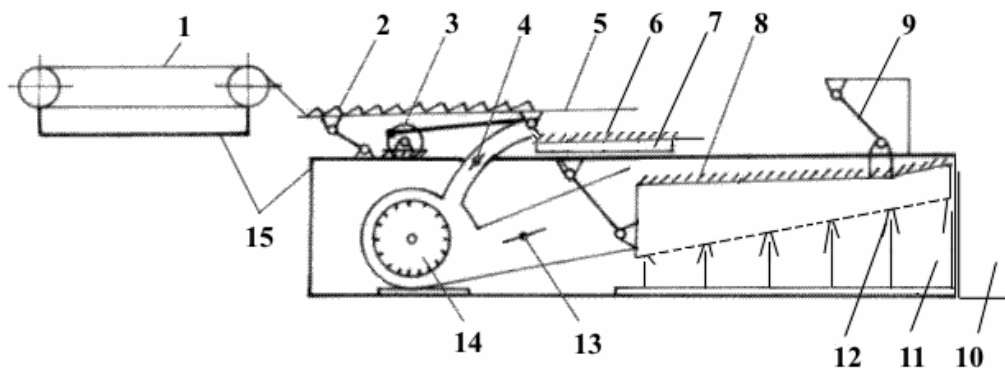

Fig. 1. Scheme of the test bench for the chaff separation of Caucasian goat's rue grasses: 1 – conveyor; 2 – straw walker; 3 – drive; 4 – extra dump of inlet duct; 5 – wire grate bars; 6 – short sieve; 7, 11 – boxes; 8 – upper sieve; 9 – rod; 10 – box; 12 – deflectors; 13 – dump of the main inlet duct; 14 – ventilator; 15 – frame.

The chaff composition of Caucasian goat's rue grasses was determined after the chaff samples of 50 g were distributed into straw pieces, leaves and pod pieces according to the length classes of 40 mm. The pieces of each length class were weighed and their percentage quantity was calculated.

Five samples were taken to determine the moisture content of chaff and seeds of the goat's rue grasses. The samples were gathered into special boxes and weighed. The topless boxes were put into the drying cabinet which had been prematurely heated to 105°C. After the chaff and seeds dried to constant mass the drying cabinet was opened, the boxes immediately closed with tops and left in the cabinet. When the chaff and seed temperature reached the temperature in the laboratory room they were weighed. The average moisture percentage was calculated from the mass difference of the moist and dry chaff and seeds. Evaluation of the results and calculation was conducted using standard statistical methods.

RESULTS AND DISCUSSION

Caucasian goat's rue grasses were harvested with combine "Sampo 500". When the rotational speed of the threshing apparatus was 120 min^{-1} , the concave positioning handle switched on the position 1, the straw pieces in the chaff comprised 45.6%, leaves – 17.5%, pod shells – 11.3%, and tiny pieces of leaves and pod shells – 25.4% (Fig. 2).

Pieces shorter than 40 mm comprised 83.4% (straw pieces – 31.8%, leaves – 16.1%, pod shells - 10.1%, pieces of pod shells – 25.4%). Straw pieces longer than 80 mm comprised only an insignificant part (about 1.5%). Because of the great amount of small pieces in the chaff, the chaff layer is denser and seeds could not penetrate it.

The chaff of Caucasian goat's rue grasses with the moisture content of $W_1= 8.7\%$, and $W_2= 22.7\%$ were fed into the chaff separation in the combine harvester cleaner test bench (Fig.1). The chaff flow rate of the grasses, oblique air flow rate in the cascades, and the gaps between the sieve openings were varied during the tests.

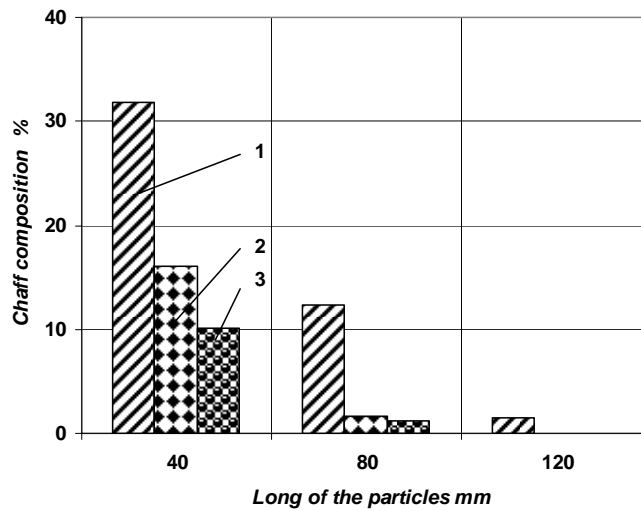

Fig. 2. Chaff composition of Caucasian goat's rue grasses: 1 – straw pieces; 2 – leaves; 3 – pod shells.

When the chaff flow rate of the goat's rue grasses was increased from 0.5 to 2.5 $\text{kg}\cdot(\text{s}\cdot\text{m})^{-1}$ the seed separation through the first part of the upper sieve decreased from 8.6 to 4.1% (Fig. 3), and through the remaining parts of the sieve it increased from 29 to 44.2%.

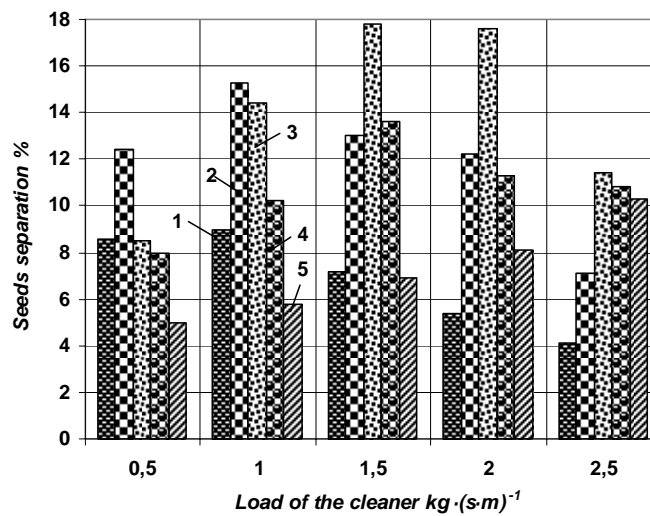

Fig. 3. Impact of the chaff flow of Caucasian goat's rue grasses on the seed separation through the upper sieve: 1 – seeds separated through the first part of the sieve; 2 - seeds separated through the second part of the sieve; 3 - seeds separated through the third part of the sieve; 4 - seeds separated through the fourth part of the sieve; 5 - seeds separated through the fifth part of the sieve.

The denser chaff layer at the beginning of the upper sieve had the greatest impact on the increase of seed separation; in addition, the lower part of the layer was compressed by the upper layer part. Seeds were trapped and could not reach the sieve openings at its beginning thus more seeds were collected in the rest boxes, and the greatest amount of the seeds together with straw was collected into box 10.

The most intensive seed separation (57.4%) through the upper sieve was when the chaff flow rate was $1.5 \text{ kg}\cdot(\text{s}\cdot\text{m})^{-1}$, and the seed cleaning losses were 12%.

When the chaff flow rate was increased to $2.5 \text{ kg}\cdot(\text{s}\cdot\text{m})^{-1}$, the seed cleanliness decreased from 80.2 to 62.6% as more chaff remained at the end of the sieve; more straw pieces, leaves and pod shells together with the seeds were separated through the sieve openings.

The air flow rate in the cascades had the greatest influence on the chaff separation through the upper sieve openings. The air flow rate in the first cascade was constant – $6 \text{ m}\cdot\text{s}^{-1}$, in the second cascade the air flow rate was varied from 4 to $7 \text{ m}\cdot\text{s}^{-1}$, and the chaff flow rate was constant $1.5 \text{ kg}\cdot(\text{s}\cdot\text{m})^{-1}$.

When the air flow rate was increased from 4 to $5 \text{ m}\cdot\text{s}^{-1}$, the seed separation through the first three parts of the upper sieve increased from 47.3 to 53.9% (Fig. 4). When the air flow rate was $7 \text{ m}\cdot\text{s}^{-1}$, the seed amount collected in the fourth and fifth boxes was 15% greater, because the chaff moved more quickly through the sieve surface as the stronger air flow blew them off further.

The seed cleanliness increased from 50.7 to 83.1% after the air flow rate was increased from 4 to $7 \text{ m}\cdot\text{s}^{-1}$, because the air flow moving at greater rates blew the chaff layer on the sieve openings, and more leaves, straw pieces and pod shells were blown from the sieve.

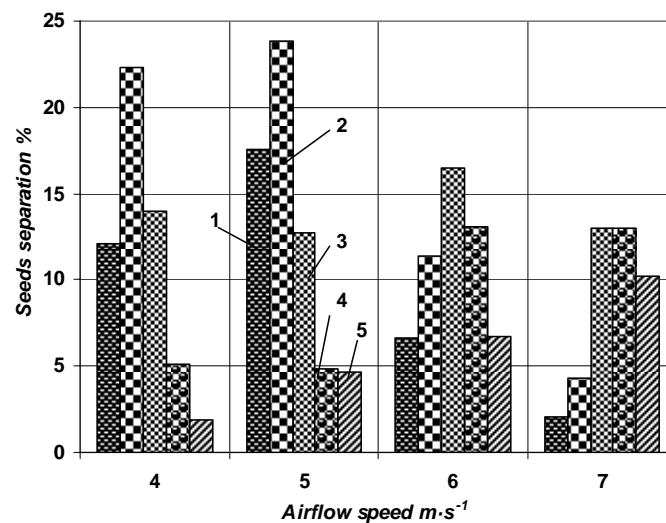

Fig. 4. Impact of air flow rate of Caucasian goat's rue grasses on the seed separation through the upper sieve: 1 – seeds separated through the first part of the sieve; 2 - seeds separated through the second part of the sieve; 3 - seeds separated through the third part of the sieve; 4 - seeds separated through the fourth part of the sieve; 5 - seeds separated through the fifth part of the sieve.

The optimum air flow rate on the second cascade and at the beginning of the upper sieve was $5 \text{ m}\cdot\text{s}^{-1}$, then approximately 53.9% of seeds and 33% of admixtures were separated through the upper sieve, and the seed cleaning losses were the least (5.2%).

The influence of the gaps in the upper sieve openings on the separation of the chaff in the upper sieve was investigated. The air flow rate in the second cascade was $5 \text{ m}\cdot\text{s}^{-1}$, the chaff flow was $1.5 \text{ kg}\cdot(\text{s}\cdot\text{m})^{-1}$.

It was determined that when the gaps in the upper sieve openings were changed, the rate and direction of the air flow also varied. When the air flow rate in the second cascade was $5 \text{ m}\cdot\text{s}^{-1}$, and the gap in the upper sieve openings was 4 mm, the air flow rate at the beginning of the sieve was $4.1 \text{ m}\cdot\text{s}^{-1}$, at the sieve end – $2.5 \text{ m}\cdot\text{s}^{-1}$. When the gaps in the sieve openings were increased to 10 mm, the air flow rate at the beginning of the sieve decreased to $0.3 \text{ m}\cdot\text{s}^{-1}$, and at the sieve end to $0.6 \text{ m}\cdot\text{s}^{-1}$.

When the gaps in the sieve openings were increased from 4 to 10 mm, the seed separation increased from 51.7 to 72.3% (Fig.5), because the sieve active separation area increased as the air flow in the sieve openings blew the lower chaff layer at the sharper angle. At the greater gaps (10 mm) of the upper sieve the seed cleaning losses decreased to 2.9%, but there were 45% of admixture in the seeds.

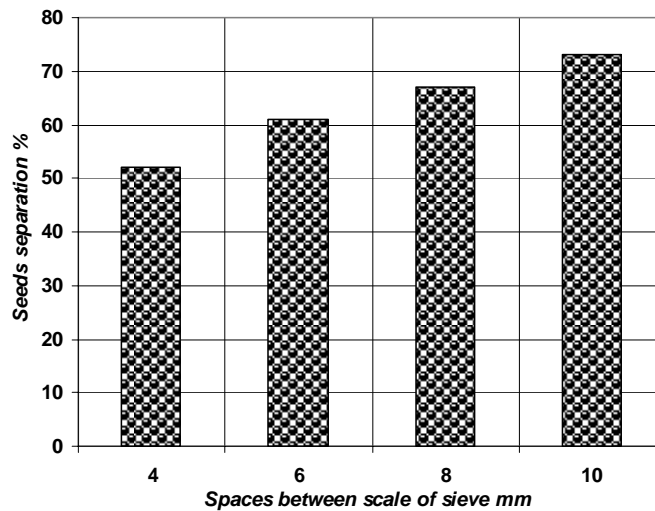

Fig. 5. Impact of gap between the sieve openings on the seed separation of Caucasian goat's rue grasses that passed through the upper sieve.

When the chaff of Caucasian goat's rue grasses is cleaned the gap of 6 mm should be left in the upper sieve openings.

CONCLUSIONS

About 80% of various pieces are smaller than 40 mm in the chaff of Caucasian goat's rue grasses. The small chaff pieces can effectively fill up the spaces between the straw pieces thus increasing the density of the chaff layer. Small seeds cannot easily penetrate through the dense chaff layer.

Tests showed that $1.5 \text{ kg}\cdot(\text{s}\cdot\text{m})^{-1}$ of Caucasian goat's rue grasses chaff could be fed into the combine harvester cleaner, then about 58% of seeds were separated through the upper sieve openings and the seed cleaning losses reached approximately 12%.

When the oblique air flow rate in the second cascade and at the beginning of the upper sieve was increased from 4 to $7 \text{ m}\cdot\text{s}^{-1}$, the seed separation decreased by about 15%. When the oblique air flow rate was $5 \text{ m}\cdot\text{s}^{-1}$, 62.2% of seeds were separated through the upper sieve openings and the seed cleaning losses decreased to 5.2%.

When the chaff of Caucasian goat's rue grasses are cleaned the recommended gap in the upper sieve openings should be 6 mm because seed cleanliness decreases when the gap is maximized to 8 mm.

REFERENCES

- Алферов, С. А., Барашев, С. А. & Эигер, М. И. 1970. Высокпроизводительная очистка с пространственным решетом // Механизация и электрификация сельского хозяйства. N 6, 30–33 (in Russian).
- Čaikauskas, V. 1995. Augalininkystė. - Vilnius, 348 (in Lithuanian).
- Dahany, A. 1993. Einfluss der Luftverteilung auf die Leistung von Mähdescherreinigungsanlagen // *Landtechnik*, 11, 597–582 (in German).
- Grobler, W. H. 1987. Untersuchungen zur Korn-Stroh-Trennung mit überlagerten Beschleunigungen im Planetentromelsortierer: Dissertation. – Stuttgart. 105 (in German).
- Jasinskas, A. & Kryževičienė, A. 2006. Energetic Grassland and the input of growing them and preparation for fuel. *Žemės ūkio inžinerija* 38(3), 59–71 (in Lithuanian).
- Kutzbach, H. D. 1992. Körnerfruchternte. Mähdescher // *Jahrbuch Agrartechnik*. N 5. 123–131 (in German).
- Kutzbach H. D. & Grobler W. H. 1981. Einrichtungen zur Kornabscheidung im Mähdescher // *Grundlagen Landtechnik* 6, 223 – 228 (in German).
- Kutzbach, H. D. 1991. Körnerfruchternte. Mähdescher // *Jahrbuch Agrartechnik*. N 4, 107–113 (in German).
- Рачис, Ю. Ю. 1987. Технологические процессы и рабочие органы для повышения эффективности уборки клевера лугового на семена с использованием комбайнов (на примере Литовской ССР) : автореф. дис. на соиск. уч. степ. канд. техн. наук. – Ленинград. 18 (in Russian).
- Рибалко, А. Г. & Пономарев, В. М. 1989. Оптимизация конструктивных параметров активного ворошителя вороха очистки зерноуборочного комбайна // Совершенствование рабочих органов уборочных машин в растениеводстве. – Саратов. 4-16 (in Russian).
- Spruogis, V. 1992. Rytinių ožiarūčių svarbesnių agrotechnikos klausimų tyrimai Lietuvoje: disertacija žemės ūkio mokslų kandidato laipsniui gauti / LŽŪA. - Kaunas-Akademija, pp. 309 (in Lithuanian).
- Srivastava, A. K., Mahoney, W. T. & West, N. L. 1990. The Effect of crop properties on combine performance Trans.// ASAE. St. Josep. - Michigan, T. 33, N 1. 63–72 (in USA).
- Степичев, М. Г. 1975. Исследование процесса разделения мелкого соломистого вороха встречным воздушным потоком : автореф. дис. на соиск. уч. степ. канд. техн. наук. – Челябинск. 26 (in Russian).
- Strakšas A. 1992. Įvairių tipų kombainų darbo rodikliai dorojant miglę bei raudonuosius dobilus // *LŽMI mokslo darbai / Vilnius.-‘Mokslas’*T.23, 61–67 (in Lithuanian).

- Špokas, L. & Vaiciukevičius, E. 2003. Research of Caucasian Goat's Rue Harvesting // Vagos: LŽŪU mokslo darbai. – Akademija. Nr. **58** (11), 111–117 (in Lithuanian).
- Vaiciukevičius, E. 1999. Rytinių ožiarūčių kūlimo tyrimai // Doktorantų mokslinės konferencijos straipsnių rinkinys "Jaunimas siekia pažangos '99". Kaunas – Akademija, pp.79–82 (in Lithuanian).
- Vaiciukevičius, E. 2002. Research of Chaff separation intensification in Combine Harvester's separator at harvesting Amaranth and Caucasian Goat's Rue : daktaro disertacija. – Kaunas,. 127p. (in Lithuanian).
- Zhao, Y. 2000. Mähdescherreinigung. Wirkung einer zusätzlicher zweiten Fallstufe // Landtechnik. N **3**, 94–95 (in German).