

Theory of grain mixture particle motion during aspiration separation

V. Bulgakov¹, S. Nikolaenko¹, I. Holovach¹, V. Adamchuk², S. Kiurchev³,
S. Ivanovs⁴ and J. Olt^{5,*}

¹National University of Life and Environmental Sciences of Ukraine, 15 Heroyiv Oborony Str., UA 03041 Kyiv, Ukraine

²National Scientific Centre, Institute for Agricultural Engineering and Electrification, 11, Vokzalna Str., Glevakcha – 1, Vasylykiv District, UA08631 Kiev Region, Ukraine

³Dmytro Motornyi Tavria State Agrotechnological University, Ukraine

⁴Latvia University of Life Sciences and Technologies, 2 Liela Str., LV-3001 Jelgava, Latvia

⁵Estonian University of Life Sciences, 56 Kreutzwaldi Str., EE51006 Tartu, Estonia

*Correspondence: jyri.olt@emu.ee

Abstract. The practice of separating grain mixtures with the use of the difference in the aerodynamic properties of their components has proved that the process of separating mixtures in the aspiration separator is the most promising one with regard to the improvement of quality and intensification of production. The authors have developed a new improved design of aspiration seed separators, in which the work process of separating seed material is performed with the use of vibration processes. In this seed material separator, the constant force air flow that acts on the sail members on the central pipe of the separator, when seeds are fed for processing, generates self-excited oscillations in the pipe, which produces centrifugal forces of inertia in the seed feeding system. As a result of the mentioned effect, the propelling force in the process under study substantially increases, accelerating the seeds of different fractions, which differ in their masses, to different velocities. The motion paths of the seed particles change accordingly, heavier particles moving closer to the vertical axis of the aspiration channel, which provides for increasing the efficiency of separation of the seeds of different fractions from each other. In this paper, a new mathematical model is developed for the motion of a seed mixture material particle in the operating space of the separator's aspiration channel. The mathematical modelling of the process of vibration and aspiration separation has indicated that the separation of the motion paths of the medium and heavy fractions takes place within the range of 20–40 mm; the flying speed of the particles is equal to 3.2–8.0 m s⁻¹, respectively; and their acceleration is equal to 1.8–3.3 m s⁻², which provides the necessary conditions for the accurate and high quality separation into the required fractions. In view of the found differences between the kinematic characteristics of the separated fractions of the grain mixture, the diameter of the pipeline for the medium fraction is to be within the range of 90–100 mm, for the heavy fraction – 50–70 mm.

Key words: air flow, aspiration separator, material particle, seed, mathematical model.

INTRODUCTION

The production of grain and oil crops has always been one of the leading industries in the world. Therefore, the issues of harvesting and initial processing of these crops, the methods of producing their seed materials as well as the scientific basis for the storage of these products are topics of current interest.

It should be noted that one of the main stages in the preparation to the storage of food grain and the seed grain for various crops is their postharvest treatment, in particular, the separation and assorting into separate fractions.

Currently, a multitude of methods exists for separating grain crops and oil plant seeds: gravity, vibration-and-centrifugal etc. At the same time, many scientists have for decades been interested in the process of separating agricultural crop seeds with the use of air flows, which allows to avoid damaging the seeds. Generally, in the existing seed-cleaning machines the process of separating seeds with the use of air flows takes place in aspiration channels of various designs, each of the latter having a number of drawbacks.

Basing on the results of the research carried out by many scientists investigating the seed separation processes, in particular, with regard to sunflower seeds, the conclusion can be arrived at that the use of vertical aspiration channels with bottom discharge is the most suitable method for these purposes. At the same time, it is desirable to generate in the discussed system of sorting the seeds into fractions self-oscillatory motion of the separator's central pipe, which will raise the separation efficiency and stabilise the motion paths of the seed material fractions.

In the early period of developing and engineering separators based on pneumatic dynamics, the separation of seeds into fractions was done in horizontal air streams, from which lighter seeds were collected in the one bin and heavier seeds in the other bin. But the quality of sorting the seeds into light and heavy fractions was low. The principal drawback in the described layout was that the horizontal air flow acted on two seeds of similar sizes and weights with two different forces: in one of the possible positions the force was maximal, in another one – minimal, and it turned out that that circumstance affected the process of good quality separation of the seed mixture. The further studies led to the development of a new seed separation process with the use of a vertical aspiration channel, in which the fed seeds interacted with the opposite-direction air stream and obtained different vertical velocities depending on the geometric shapes and masses of the seeds. As a result of that, all the seeds got into the position of the lowest aerodynamic drag with regard to the vertical airflow and, due to the quasi fluid-drop shape of the surfaces of the particles, the Joukowski lifting force arose, which improved the conditions for separating the particles onto different motion paths. However, in this case again the precision of the seed separation into fractions on account of the different air flows proved to be insufficient.

Today, a sufficiently large number of various designs exists. Among them, there are designs with a vertical aspiration channel, but the currently available mechanical means for seed separation feature the following major drawbacks: sophisticated adjustment, high power consumption, low quality of separating seeds into fractions and insufficient accuracy in operation with seeds of different moisture content.

The above-mentioned shortcomings are to some extent made even, when using the already developed design of the pneumatic and gravity seed separator with bottom

separation of the fractions. In that case, the aspiration separator of a rather simple design delivers high productivity in the separation of loose dry materials and provides for the handling of multiple-fraction mixtures.

The said design is further developed in the new vibrating pneumatic dynamics unit devised by the authors, which provides for the improvement of the separation quality indicators in the processing of oil crop seeds, in particular, sunflower seeds. The process flow diagram of the new design of vibration and aspiration separator is presented in Fig. 1.

The vibration and aspiration separator under consideration comprises the feeding chute 1 of a conical shape, from which the seed material flows from above onto the central pipe 2. The upper end of the central pipe 2 features the conical spreader 3. The central pipe 2 is situated inside the fixed channel 4 (stationary pipe) in such a way that a cylindrically shaped space appears between the pipe 2 and the channel 4 and in the middle of that space the work process of grain mixture separation takes place. The central pipe 2 is connected to the stationary channel 4 with springing members 5, which are installed in the upper and lower areas, aligned radially and retain the pipe 2 in the position shown in Fig. 1. On the outer (cylindrical) surface of the central pipe 2 the sail members 6 are fixed, which have pre-set sizes and are positioned on the pipe 2 in the form of a provisional spiral. The angle of lead of the said spiral is 45° with respect to the longitudinal axis of the central pipe 2. The lower part of the separator features the elbow pipes 7 and 8 for the intake and further carrying away of the heavy and medium seed fractions, respectively. The process flow diagram features the seeds of the light 9, medium 10 and heavy 11 fractions together with the indication of their motion directions (shown by the short arrows).

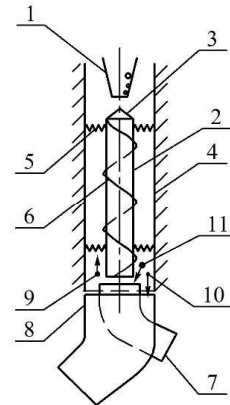

Figure 1. Process flow diagram of vibration and aspiration separator: 1 – feeding chute; 2 – central pipe; 3 – conical spreader of central pipe; 4 – stationary channel; 5 – springing members; 6 – sail members; 7 – heavy fraction discharge pipe; 8 – medium fraction discharge pipe; 9 – light fraction seeds; 10 – medium fraction seeds; 11 – heavy fraction seeds.

During the operation of the aspiration seed separator, the exhaust fan (not shown in the diagram in Fig. 1) generates a stream of air moving from the bottom upwards in the stationary channel 4, which applies pressure to the sail members 6 situated on the outer surface of the central pipe 2. That results in the generation of external forces applied to them and those forces make the pipe 2 rotate about its vertical axis. The springing members 5 arrest, after their respective deformation, the described rotary motion of the central pipe 2 in one direction. Since the air flow varies as a consequence of the variation of the effective cross-section (that is, the space between the outer surface of the central pipe 2 and the internal surface of the stationary channel 4 being filled with the seeds fed from the top downwards), the external forces applied to the sail members 6 vary as well, which results in the change of the direction of rotation of the central pipe 2, which starts

rotating in the opposite direction. Thus, the cycle of action of the variable force factors imparted to the seed material fed from above onto the conical spreader 3 of the central pipe 2 recurs. In this way, the devised mechanical system generates the self-oscillatory mode of motion of the principal operating device, i.e. the central pipe 2, onto which seed material is fed for separation from the feeding chute 1 situated above it. Due to the self-oscillatory motions, the conical spreader 3 situated at the top of the central pipe 2 imparts to the seeds (considered as material particles) different kinematic and force parameters (in effect, conditioned by the said self-oscillations), which results in the seeds being evenly distributed along the cone base circumference and then input into the space between the pipe 2 and the channel 4. Further, under the action of the counter-current flow of air that applies forces to every material particle, the separated seeds fall down, but moving along different paths of motion. For example, the stream of the flowing up air immediately carries up and away from the separator the seeds of the light fraction 9 (dust and other light impurities), while the medium fraction seeds 10 in their downward travel eventually concentrate nearer to the internal surface of the stationary channel 4 and, on their arrival to the bottom part of the separator, are carried away via the pipe 8 away from the separator. Finally, the heavy fraction seeds 11 sinking closer to the outer surface of the central pipe 2 are discharged via the pipe 7 in the respective direction away from the aspiration separator.

As a result of the above-mentioned angular self-oscillations, during the rotation of the central pipe 2 about the vertical axis of the separator, the field of centrifugal forces of inertia emerges. As a consequence, the propelling force of the seed medium separation process under consideration increases and accelerates the seeds of different fractions that differ in their masses to different velocities. The motion paths of the particles change respectively, that is, their separation takes place, which facilitates improvement of the efficiency of dividing the seeds into separate fractions. Depending on their masses, the seeds move down either into the pipe 7 for the discharge of the heavy fraction, the diameter of which, in accordance with the results of the experimental research and pilot tests, has to be equal to 70 mm, or into the pipe 8 for the discharge of the medium fraction, also situated at the bottom, the diameter of which has to be equal to at least 160 mm. Meanwhile, the seeds in the light fraction with masses not exceeding 40 mg, as noted above, are quite easily picked up by the stream of air, fly upwards, in the opposite direction, and are separately collected at the top, which fully completes the operating cycle of seed material separation.

Thus, the work process of grain mixture separation takes place under the above-described conditions. At the same time, the self-oscillations of the central pipe 2 together with the conical spreader 3 facilitate the considerable intensification of the process of dividing the seed mixture into separate components.

Basing on the completed engineering developments, experimental studies and production tests, it is possible to infer that the new aspiration-and-vibration separation system offers the following advantages:

- minimised costs due to the fact that the self-oscillatory mode of operation significantly intensifies the separation process and does not require any special mechanism for impelling the self-oscillatory motion;
- only part of the power consumed by the pressure fan is used for maintaining the self-oscillatory mode of operation of the principal operating device that imparts its parameters to the seed mixture components;

– simplicity of design and the minimal costs of modernisation and maintenance, which imply only providing the movability of the central pipe and the possibility to attach sail members of different sizes to it.

The research into the theoretical and practical basis of the separation of grain crop seeds is represented in the papers (Poturayev & Franchuk, 1970; Burkov, 1991; Kotov, 2002; Leshchenko & Vasilkovsky, 2009; Brăcăcescu et al., 2012; Kyurchev & Kolodiy, 2015; Kroulik et al., 2016; Saitov et al., 2016; Saitov et al., 2018; Badretidinov et al., 2019; Brăcăcescu et al., 2019). It is to be noted that the mentioned studies pay attention to the parameters that have effect on the velocity of soaring of the grain particles, that is, the interaction between the seeds and the counter flow of air. The further research has proved that the said velocity depends on quite a number of factors: the masses of the seeds, the aerodynamic drag factor, the maximum cross-section of each type of seeds, the space orientation of the seeds etc. The authors of the above-mentioned studies have arrived to their conclusions basing on the results of research, but they are correct only under specific conditions.

In the paper (Kyurchev & Kolodiy, 2012), the effect of the design parameters of the conical aspiration channel on the kinetic properties of the motion of seeds is examined. In the paper (Bernik & Palamarchuk, 1996), the relations are obtained for the dynamics of the motion of particles in the air flow and the efficiency of air cleaning in the operating space of the vertical aspiration channel. The paper (Vasilkovsky et al., 2007) presents the study and justification of the possibility to separate seeds not only by weight, but also by size with the use of an inclined air flow. After revealing the principal rules that govern the process with the use of the devised pneumatic and centrifugal separator equipped with a spreading disk, it became possible to improve the quality of the seed distribution. In the current paper, the authors propose using a vertical aspiration channel with bottom discharge and generating the self-oscillatory motion of the separator's central pipe in order to increase substantially the propelling force of the process and the separation of the motion paths of the seed material fractions.

The aim of the study is to improve the productivity and quality of the loose seed mixture separation by means of developing a new design of the aspiration separator and theoretically substantiating its rational parameters.

MATERIALS AND METHODS

In order to substantiate theoretically the main parameters of the aspiration sunflower seed separator, it is necessary first of all to examine the process of self-oscillations of the separator's central pipe as one of the principal elements in the discussed method of separating the seeds into the required fractions.

It is to be noted that the self-oscillatory motion of the separator's central pipe is generated under the action of a number of perturbing force factors and the restoring forces of its springing members.

Therefore, it is necessary to start with generating the equivalent schematic model of the central pipe of the vibration and aspiration separator, indicating in it all the perturbing forces and the restoring springing members (Fig. 2).

For the purpose of describing the force interaction between the central pipe and the air stream and the self-oscillatory motion of the central pipe about the vertical axis of the separator, it is necessary to set up the fixed Cartesian reference system $Oxyz$, the

origin of which (point O) is situated at the centre of the upper base of the central pipe, that is, the lower base of its spreading cone, the Ox axis is aligned horizontally to the right, the Oy axis is aligned vertically down along the central axis of the aspiration channel and the Oz axis is situated in the horizontal plane and directed perpendicularly to the Oxy plane (Fig. 2).

The first step is to consider the forces shown in the equivalent schematic model that act on the central pipe and determine their values. The perturbing force factors include the force \bar{F}_{af} of the air flow, which acts on the sail member generating the moment of rotation M_d that rotates the central pipe about the vertical axis Oy . The restoring forces of the springing members include the elastic resistance force \bar{R}_r and the moment of rotation $M_{r\varphi}$ of the elastic forces of resistance during the rotation of the central pipe about the vertical axis Oy . In the equivalent schematic model, the springing members that connect the central pipe with the stationary channel of the separator at the top and the bottom of the channel and have elastic coefficients C_x and C_z are shown.

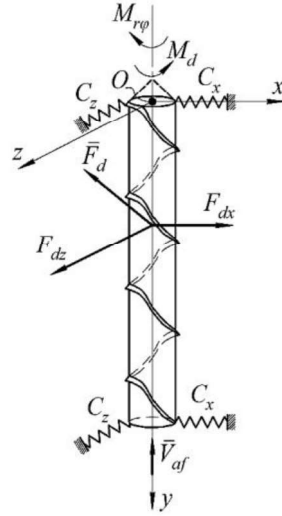

Figure 2. Equivalent schematic model of central pipe of vibration and aspiration separator.

RESULTS

The next step is to find the analytic expressions for the above-mentioned force factors. The moment of rotation M_d applied to the central pipe is determined by the following expression:

$$M_d = F_{af} \cdot r_D \cdot \sin \omega t \quad (1)$$

where r_d – radius of the central pipe of the separator; ω – angular velocity of rotation of the central pipe about the longitudinal axis (axis Oy).

The components of the restoring force \bar{R}_r , vectored along the Ox and Oz axes are equal to, respectively:

$$R_{rx} = C_x \cdot x, \quad (2)$$

$$R_{rz} = C_z \cdot z, \quad (3)$$

where C_x and C_z – springing member stiffness factors along the Ox and Oz axes, respectively; x and z – deformations of the springing members in case of the central pipe's deviation from the vertical axis.

The moment of the elastic forces that act during the rotation of the central pipe about the longitudinal axis (about the Oy axis) is equal to:

$$M_{r\varphi} = C_\varphi \cdot \varphi, \quad (4)$$

where C_φ – total stiffness factor of the springing members in case of the central pipe’s rotation about the Oy axis; φ – angular displacement of the central pipe.

When the central pipe rotates (performs angular oscillations) about the vertical axis of the separator, i.e. about the Oy axis, the field of centrifugal forces of inertia emerges as a result of the deviation of the pipe’s cross-section from the axis of rotation. The said forces of inertia can be represented by the equivalent force of inertia \vec{F}_{d_i} . In this case, the components of the above-mentioned centrifugal forces vectored along the Ox and Oz coordinate axes can be represented in the form of their projections on the said axes, which are equal to, respectively:

$$F_{dx} = m_D \cdot l_x \cdot \omega^2 \sin \omega t, \quad (5)$$

$$F_{dz} = m_D \cdot l_z \cdot \omega^2 \sin \omega t. \quad (6)$$

where m_D – mass of the central pipe; l_x and l_z – deviations of the cross-section of the central pipe from the axis of rotation (vertical axis of the separator); ω – angular velocity of the pipe’s rotation about the vertical axis of the separator.

The schematic model of the deviation of the central pipe’s cross-section that intersects the central pipe’s centre of gravity, which occurs under the action of the forces of inertia, is shown in Fig. 3. In this deviation, the pipe’s centre and accordingly the origin of the system of coordinates $Oxyz$ takes the new position (O_1), shifting along the Ox axis by an amount of l_x .

Upon reaching a certain position in the process of the discussed rotation, the moment of rotation M_b becomes counterbalanced by the moment of elastic forces $M_{r\varphi}$, in consequence of which the angular velocity ω of the central pipe’s rotation becomes equal to zero, the centrifugal forces disappear and the central pipe stops rotating in this direction, then it starts rotating in the opposite direction also

under the action of the moment of elastic forces, thus performing angular oscillatory motion in the other direction. This sequence occurs periodically.

Thus, consideration has been given to all the force factors causing self-oscillation of the central pipe and, as a result of the self-oscillation, generation of the necessary centrifugal forces of inertia involved in the separation of the seed flow into the required fractions.

Further, it is necessary to analyse the movement of the seeds under the effect of the air flow and the generated centrifugal forces of inertia applied to the seeds, using the same system of coordinates $Oxyz$.

As the seeds moving in the flow are connected via friction forces with the surface of the central pipe and sail members and also connected via internal friction forces with each other in the said flow, the above-mentioned centrifugal forces act on the seeds and

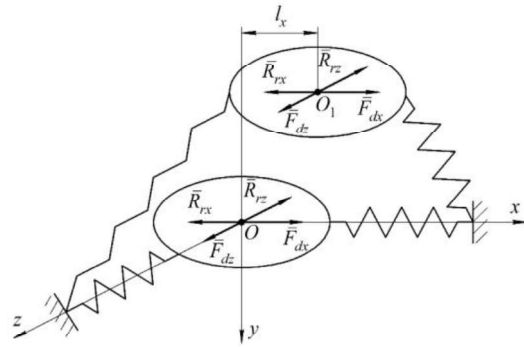

Figure 3. Schematic model of linear displacement of central cross-section intersecting centre of gravity O of central pipe: O , O_1 – positions of cross-section before and after displacement, respectively.

impart to them different velocities depending on their masses.

Besides, each individual flow particle (seed) is under the action of the force of gravity \bar{G} , the magnitude of which is equal, as is known, to:

$$G = m_s \cdot g, \quad (7)$$

where m_s – mass of the particle (seed), g – acceleration of gravity.

Moreover, the material particle (seed) is under the action of the air flow resistance force \bar{R} , the magnitude of which can be determined with the use of the following expression:

$$R = k_c (V_s - V_{af})^2 \quad (8)$$

where k_c – coefficient representing the properties of the material particles (seeds) and the medium, in which they move; ξ – coefficient of resistance of the medium, $k_c = \xi \cdot S_M \cdot \frac{\rho}{2}$; S_M – area of the midsection of the particle (seed); ρ – density of the air; V_s – velocity of the material particle (seed); V_{af} – air velocity.

In order to describe the motion of the material particle M (sunflower seed) performed under the action of the above-mentioned forces, a separate equivalent schematic model has been generated (Fig. 4). In the equivalent schematic model, the material particle M is shown at an arbitrary position. The centrifugal forces of inertia represented by the equivalent force of inertia \bar{F}_d that act on the central pipe are imparted to the material particles as perturbing forces, which can also be represented by their projections \bar{F}_{dx} , \bar{F}_{dz} on the respective coordinate axes Ox and Oz .

Taking into account the obtained schematic model of system forces represented in the above equivalent schematic model and on using Newton's second law of motion, it is possible to generate the system of differential equations that describes the motion of the material particle M (seed) in the central part of the aspiration channel. The system of differential equations appears as follows:

$$\left. \begin{aligned} m_s \ddot{x} &= F_{dx} - R_{rx}, \\ m_s \ddot{y} &= G_s - F_{af} + R, \\ m_s \ddot{z} &= F_{dz} - R_{rz}. \end{aligned} \right\} \quad (9)$$

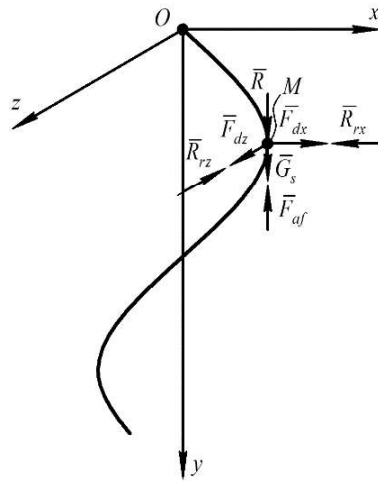

Figure 4. Equivalent schematic model of motion of material particle M (sunflower seed) under action of forces applied to it: \bar{F}_{dx} , \bar{F}_{dz} – components of perturbing force \bar{F}_d , which causes vibrations of central pipe; \bar{F}_{af} – air flow force; \bar{G} – seed gravity force; \bar{R} – resistance of air; \bar{R}_{rx} , \bar{R}_{rz} – elastic forces.

Taking into account the expressions (2), (5)–(8) and performing certain transformations, the system of differential equations (9) can be transformed into the following system:

$$\left. \begin{aligned} \ddot{x} + \frac{C_x}{m_s} \cdot x &= \frac{m_D}{m_s} \cdot l_x \cdot \omega^2 \cdot \sin\omega t, \\ \ddot{y} &= g - \frac{F_{af}}{m_s} + \frac{k_c}{m_s} (V_s - V_{af})^2, \\ \ddot{z} + \frac{C_z}{m_s} \cdot z &= \frac{m_D}{m_s} \cdot l_z \cdot \omega^2 \cdot \sin\omega t. \end{aligned} \right\} \quad (10)$$

It is obvious that each differential equation in the system (10) can be solved individually.

The following designations are introduced for solving the first equation of the system (10):

$$\frac{m_D}{m_s} \cdot l_x \cdot \omega^2 = D_x, \quad \frac{C_x}{m_s} = k_x^2. \quad (11)$$

With such designations, the first equation of the system (10) is reduced to the following expression:

$$\ddot{x} + k_x^2 x = D_x \sin\omega t. \quad (12)$$

The general solution of the differential equation (12) is sought in the following form:

$$x = \bar{x} + x^*, \quad (13)$$

where \bar{x} – general solution of the homogeneous equation (without the right member); x^* – partial solution of the differential equation with the right member.

As is known, the general solution of the homogeneous equation appears as follows:

$$\bar{x} = C_1 \cdot \cos k_x t + C_2 \cdot \sin k_x t, \quad (14)$$

where C_1 and C_2 – arbitrary constants.

The partial solution x^* is sought in the following form:

$$x^* = B_1 \cdot \sin\omega t + B_2 \cdot \cos\omega t, \quad (15)$$

where B_1 and B_2 – coefficients that can be found with the use of the method of undetermined coefficients.

Employing the said method, the following is obtained:

$$B_1 = \frac{D_x}{k_x^2 - \omega^2}, \quad k_x^2 \neq \omega^2, \quad B_2 = 0 \quad (16)$$

Hence, the partial solution obtains the following form:

$$x^* = \frac{D_x}{k_x^2 - \omega^2} \cdot \sin\omega t \quad (17)$$

Then, by substituting (14) and (17) into (13), the following is arrived at:

$$x = C_1 \cdot \cos k_x t + C_2 \cdot \sin k_x t + \frac{D_x}{k_x^2 - \omega^2} \cdot \sin\omega t \quad (18)$$

After differentiating the expression (18) with respect to time t , the following is obtained:

$$\dot{x} = C_1 \cdot k_x \cdot \sin k_x t + C_2 \cdot k_x \cdot \cos k_x t + \frac{D_x \cdot \omega \cdot \cos \omega t}{k_x^2 - \omega^2} \quad (19)$$

When the initial conditions are taken into account:

at $t = 0$: $x_0 = a$, $\dot{x}_0 = V_{x0} = 0.7 \text{ m s}^{-1}$

the following is derived from the expressions (18) and (19):

$$\begin{aligned} C_1 &= a, \\ C_2 &= \frac{0.7}{k_x} - \frac{D_x \cdot \omega}{(k_x^2 - \omega^2) \cdot k_x} \end{aligned} \quad (20)$$

where a – original coordinate of the position of the material particle M on the curved path featured in the equivalent schematic model.

After substituting (20) into (18), the resulting expression is:

$$x = a \cdot \cos k_x t + \left[\frac{0.7}{k_x} - \frac{D_x \omega}{(k_x^2 - \omega^2) k_x} \right] \sin k_x t + \frac{D_x}{k_x^2 - \omega^2} \sin \omega t \quad (21)$$

Under steady-state conditions, the first two components of the expression (21) tend to zero, because they represent the natural oscillations of the system, which are damped oscillations, therefore, the obtained solution takes the following form:

$$x = \frac{D_x \cdot \sin \omega t}{k_x^2 - \omega^2}. \quad (22)$$

In a similar way, after solving the third differential equation of the system (10), the following is arrived at:

$$z = \frac{D_z \cdot \sin \omega t}{k_z^2 - \omega^2} \quad (23)$$

where

$$D_z = \frac{m_D}{m_s} l_z \omega^2, \quad k_z^2 = \frac{c_z}{m_s}. \quad (24)$$

Further, the angular velocity ω of the central pipe rotation about the vertical axis of the aspiration separator can be expressed in terms of the latter's design and dynamic parameters.

For that purpose, the maximum values of the centrifugal forces arising during the rotation of the central pipe have to be analysed.

Taking into account (5) and (6), the following is obtained:

$$F_{dx_{max}} = m_D \cdot l_{x_{max}} \cdot \omega^2, \quad F_{dz_{max}} = m_D \cdot l_{z_{max}} \cdot \omega^2. \quad (25)$$

On the other hand:

$$F_{dx_{max}} = F_{af} \cdot \sin \alpha, \quad F_{dz_{max}} = F_{af} \cdot \cos \alpha. \quad (26)$$

where F_{af} – air flow force; α – angle of tilt of the sail element spiral's axis with respect to the longitudinal axis of the pipe.

As stated above, $\alpha = 45^\circ$.

In view of that circumstance, the following is obtained:

$$F_{dx_{max}} = F_{dz_{max}} = \frac{\sqrt{2}}{2} \cdot F_{af} = \frac{F_{af}}{\sqrt{2}}. \quad (27)$$

Due to the symmetry considerations, it is assumed that:

$$l_{x_{max}} = l_{z_{max}} = l.$$

Subsequently, by equating (25) and (27) and replacing $l_{x_{max}}$ and $l_{z_{max}}$ with l , the following is arrived at:

$$m_D \cdot l \cdot \omega^2 = \frac{F_{af}}{\sqrt{2}},$$

from which follows:

$$\omega^2 = \frac{F_{af}}{\sqrt{2} \cdot m_D \cdot l}. \quad (28)$$

Hence:

$$\omega = \sqrt{\frac{F_{af}}{\sqrt{2} \cdot m_D \cdot l}} \quad (29)$$

Further, after substituting the expression (28) into the expression (11), the following is obtained:

$$D_x = \frac{m_D}{m_S} l_x \omega^2 = \frac{m_D}{m_S} l_x \cdot \frac{F_{af}}{\sqrt{2} \cdot m_D \cdot l} = \frac{F_{af}}{\sqrt{2} \cdot m_S} \cdot \frac{l_x}{l} \quad (30)$$

Similarly:

$$D_z = \frac{m_D}{m_S} l_z \omega^2 = \frac{m_D}{m_S} l_z \cdot \frac{F_{af}}{\sqrt{2} \cdot m_D \cdot l} = \frac{F_{af}}{\sqrt{2} \cdot m_S} \cdot \frac{l_z}{l} \quad (31)$$

After (30) is substituted into the expression (22), the result is:

$$\begin{aligned} x &= \frac{F_{af}}{\sqrt{2} \cdot m_S} \cdot \frac{l_x}{l} \cdot \frac{\sin \omega t}{k_x^2 - \omega^2} = \frac{F_{af}}{\sqrt{2} \cdot m_S} \cdot \frac{l_x}{l} \cdot \frac{\sin \omega t}{C_x - \frac{F_{af}}{\sqrt{2} \cdot m_D \cdot l}} = \\ &= \frac{l_x \cdot F_{af} \cdot \sin \omega t}{l \cdot \sqrt{2} \left(C_x - \frac{m_S \cdot F_{af}}{m_D \cdot l} \right)}. \end{aligned} \quad (32)$$

Similarly:

$$\begin{aligned} z &= \frac{F_{af}}{\sqrt{2} \cdot m_S} \cdot \frac{l_z}{l} \cdot \frac{\sin \omega t}{k_z^2 - \omega^2} = \frac{F_{af}}{\sqrt{2} \cdot m_S} \cdot \frac{l_z}{l} \cdot \frac{\sin \omega t}{C_z - \frac{F_{af}}{\sqrt{2} \cdot m_D \cdot l}} = \\ &= \frac{l_z \cdot F_{af} \cdot \sin \omega t}{l \cdot \sqrt{2} \left(C_z - \frac{m_S \cdot F_{af}}{m_D \cdot l} \right)}. \end{aligned} \quad (33)$$

The expressions (32) and (33) define the law of the particle (seed) displacement as a function of time t with provisions for the design and dynamic parameters of the aspiration separator.

The complete displacement S of the material particle M (sunflower seed) in the cross-section of the aspiration channel is equal to:

$$S = \sqrt{x^2 + y^2} \quad (34)$$

or, taking into account (32) and (33):

$$S = \frac{F_{af}}{l \cdot \sqrt{2}} \cdot \sin \omega t \cdot \sqrt{\frac{l_x^2}{\left(C_x - \frac{m_S \cdot F_{af}}{m_D \cdot l}\right)^2} + \frac{l_z^2}{\left(C_z - \frac{m_S \cdot F_{af}}{m_D \cdot l}\right)^2}} \quad (35)$$

Further, by substituting the expression (28) into the expressions (5) and (6), the following is obtained:

$$F_{dx} = m_D \cdot l_x \cdot \frac{F_{af}}{\sqrt{2} \cdot m_D \cdot l} \cdot \sin \omega t = \frac{l_x \cdot F_{af} \cdot \sin \omega t}{\sqrt{2} \cdot l} \quad (36)$$

$$F_{dz} = m_D \cdot l_z \cdot \frac{F_{af}}{\sqrt{2} \cdot m_D \cdot l} \cdot \sin \omega t = \frac{l_z \cdot F_{af} \cdot \sin \omega t}{\sqrt{2} \cdot l} \quad (37)$$

The centrifugal force F_d is equal to:

$$F_d = \sqrt{F_{dx}^2 + F_{dz}^2} \quad (38)$$

or

$$F_d = \frac{F_{af}}{\sqrt{2} \cdot l} \cdot \sin \omega t \cdot \sqrt{l_x^2 + l_z^2} \quad (39)$$

Finally, after the expressions (32), (33) are substituted into the expressions (2) and (3), the following is arrived at:

$$R_{rx} = \frac{C_x \cdot l_x \cdot F_{af} \cdot \sin \omega t}{l \cdot \sqrt{2} \left(C_x - \frac{m_S \cdot F_{af}}{m_D \cdot l}\right)} \quad (40)$$

$$R_{rz} = \frac{C_z \cdot l_z \cdot F_{af} \cdot \sin \omega t}{l \cdot \sqrt{2} \left(C_z - \frac{m_S \cdot F_{af}}{m_D \cdot l}\right)} \quad (41)$$

The final value of R_r is equal to:

$$R_r = \sqrt{R_{rx}^2 + R_{rz}^2} \quad (42)$$

or

$$R_r = \frac{F_{af} \cdot \sin \omega t}{l \cdot \sqrt{2}} \cdot \sqrt{\frac{C_x^2 \cdot l_x^2}{\left(C_x - \frac{m_S \cdot F_{af}}{m_D \cdot l}\right)^2} + \frac{C_z^2 \cdot l_z^2}{\left(C_z - \frac{m_S \cdot F_{af}}{m_D \cdot l}\right)^2}} \quad (43)$$

Thus, the analytic expressions have been obtained that allow to determine the perturbing forces and elastic resistance forces expressed in terms of the design and dynamic parameters of the aspiration separator that provide for the performance of the work process under consideration.

The next task is to find out the velocities and accelerations of the material particles (seeds) in the work process under consideration.

The velocity of the seeds can be determined in terms of its projections on the x and z axes. That is:

$$V_x = \dot{x} = \frac{l_x \cdot F_{af} \cdot \omega \cdot \cos \omega t}{l \cdot \sqrt{2} \left(C_x - \frac{m_s \cdot F_{af}}{m_D \cdot l} \right)} = \frac{l_x \cdot F_{af} \cdot \sqrt{\frac{F_{af}}{\sqrt{2} \cdot m_D \cdot l}} \cdot \cos \omega t}{l \cdot \sqrt{2} \left(C_x - \frac{m_s \cdot F_{af}}{m_D \cdot l} \right)} \quad (44)$$

and

$$V_z = \dot{z} = \frac{l_z \cdot F_{af} \cdot \omega \cdot \cos \omega t}{l \cdot \sqrt{2} \left(C_z - \frac{m_s \cdot F_{af}}{m_D \cdot l} \right)} = \frac{l_z \cdot F_{af} \cdot \sqrt{\frac{F_{af}}{\sqrt{2} \cdot m_D \cdot l}} \cdot \cos \omega t}{l \cdot \sqrt{2} \left(C_z - \frac{m_s \cdot F_{af}}{m_D \cdot l} \right)} \quad (45)$$

As is known, the total velocity is equal to:

$$V = \sqrt{V_x^2 + V_z^2} \quad (46)$$

or

$$V = \frac{F_{af} \cdot \sqrt{\frac{F_{af}}{l \cdot m_D \cdot \sqrt{2}}} \cdot \cos \omega t}{l \cdot \sqrt{2}} \cdot \sqrt{\frac{l_x^2}{\left(C_x - \frac{m_s \cdot F_{af}}{m_D \cdot l} \right)^2} + \frac{l_z^2}{\left(C_z - \frac{m_s \cdot F_{af}}{m_D \cdot l} \right)^2}} \quad (47)$$

The acceleration of the seeds is also determined in terms of its projections on the Ox and Oz axes. That is:

$$a_x = \ddot{x} = -\frac{l_x \cdot F_{af}^2 \cdot \sin \omega t}{2 \cdot l^2 \cdot m_D \left(C_x - \frac{m_s \cdot F_{af}}{m_D \cdot l} \right)} \quad (48)$$

and

$$a_z = \ddot{z} = -\frac{l_z \cdot F_{af}^2 \cdot \sin \omega t}{2 \cdot l^2 \cdot m_D \left(C_z - \frac{m_s \cdot F_{af}}{m_D \cdot l} \right)} \quad (49)$$

As is known, the total acceleration is equal to:

$$a = \sqrt{a_x^2 + a_z^2} \quad (50)$$

or

$$a = \frac{F_{af}^2 \cdot \sin \omega t}{2 \cdot l^2 \cdot m_D} \cdot \sqrt{\frac{l_x^2}{\left(C_x - \frac{m_s \cdot F_{af}}{m_D \cdot l} \right)^2} + \frac{l_z^2}{\left(C_z - \frac{m_s \cdot F_{af}}{m_D \cdot l} \right)^2}} \quad (51)$$

DISCUSSION

On the basis of the obtained relations, the kinematic and force characteristic curves of the researched process have been plotted with the use of the specially developed computation program in the MathCAD environment. When determining the amount of the displacement of sunflower seeds, their different masses were taken into account, that is, the following seed mass limit values were used in the PC-assisted numerical calculations for the heavy and medium fractions:

- medium fraction $m_{SI} = 0.040\text{--}0.060$ g;
- heavy fraction $m_{SI} = 0.065\text{--}0.080$ g.

The kinematic parameters taken into consideration included the displacement S , velocity V and acceleration a of the seeds in the fractions under study.

The above-said parameters were calculated in relation to the angular displacement $\varphi = \omega t$ of the central pipe in the vibration and aspiration separator of sunflower seeds.

Thus, the diagrams shown in Fig. 6 give evidence of the substantial difference in the distance covered by the seeds of the medium and heavy fractions in the radial (transverse) plane of the aspiration separator, especially for the angular displacement φ of the central pipe within the range of 200° to 335° , in which case the said difference reaches 20 to 40 mm, respectively.

That indicates the substantial influence of the field of centrifugal forces of inertia on the process of separation of sunflower seeds into fractions within the above-mentioned (main) range of the angular displacement of the separator's central pipe, which translates into the high quality of operation in the examined work process of seed mixture separation. The said influence is especially pronounced at the instant, when the central pipe rotates through an angle of 270° . As is seen from the curves presented in the figure, in the absence of the action of centrifugal forces (when the angular displacement of the central pipe is equal to 180° or 360°) virtually no separation of the seeds into fractions takes place.

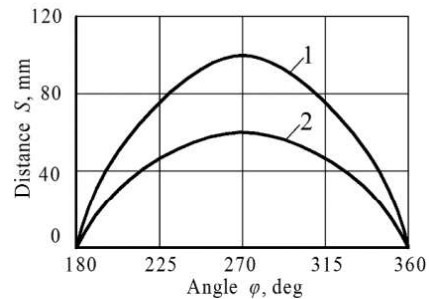

Figure 6. Relation between covered distance and angular displacement φ of central pipe for medium (1) and heavy (2) fractions of sunflower seed mixture.

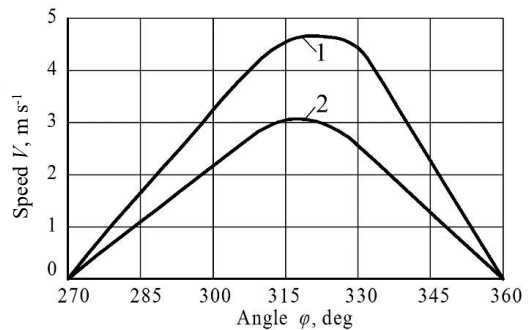

Figure 7. Relations between velocity of seeds of medium (1) and heavy (2) fractions and angular displacement φ in radial plane of central pipe.

Similar diagrams have been plotted for the relations between the maximum velocities of the motion of sunflower seeds in the radial plane and the angular displacement φ of the central pipe for each of the above-mentioned fractions (Fig. 7).

As is seen on the diagrams presented in Fig. 7, the maximum velocity of sunflower seeds in the heavy fraction is equal to 4.5 m s^{-1} , while in case of the medium fraction – 3.0 m s^{-1} . Also, the difference between the velocities of seeds in the medium and heavy fractions is equal to $0.6\text{--}1.5 \text{ m s}^{-1}$, when the angular displacement φ of the central pipe varies within the range of $285^\circ\text{--}345^\circ$. This difference between the velocities of particles in the medium and heavy fractions is exactly what facilitates the separation of the seeds into fractions.

The diagrams in Fig. 8 represent the relations between the acceleration of sunflower seeds in each of the fractions and the angular displacement φ of the central pipe of the vibration and aspiration separator.

As is seen on the diagrams shown in Fig. 8, the maximum acceleration of sunflower seeds in the heavy fraction is equal to 3.3 m s^{-2} , in the medium fraction – 1.9 m s^{-2} . Also, it is evident from the data of the diagrams that for the angular displacement φ of the central pipe within the range of $200^\circ\text{--}335^\circ$ the difference between the accelerations of seeds in the medium and heavy fractions is equal to $0.7\text{--}1.4 \text{ m s}^{-2}$, which again contributes to improving the quality of the separation of the seed mixture into fractions.

With the use of PC-assisted calculations, the authors have also determined the power consumption indicators for the discussed work process of separating sunflower seeds with the use of a vibration and aspiration separator.

The relations presented in Fig. 9 specify the variation of magnitude of the perturbing (centrifugal) force that arises, when self-oscillatory motion is generated in the components of the separated mixture. In case of the heavy fraction of sunflower seeds, its maximum value is equal to 100 N , for the seeds in the medium fraction – 68 N . Therefore, the difference in this indicator amounts to 32%.

It is logical to assume that the centrifugal force acting on the heavier seeds is greater than that acting on the medium fraction seeds, since it depends on the mass of the seed.

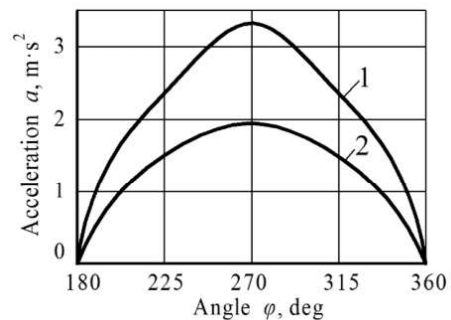

Figure 8. Relation between acceleration of sunflower seeds in heavy (1) and medium (2) fractions and angular displacement φ of central pipe.

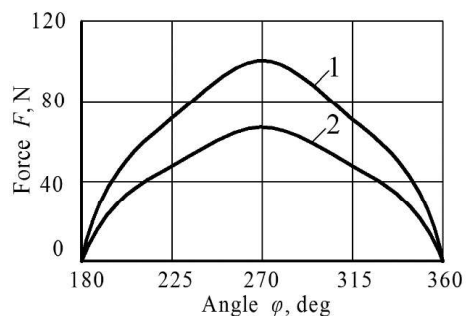

Figure 9. Relations between magnitude of perturbing force and angular displacement φ of central pipe for seeds in heavy (1) and medium (2) fractions, respectively.

The difference between the centrifugal forces acting on the particles (seeds), as shown in the diagrams (Fig. 9), is the exact cause of the separation of the seeds into fractions.

Calculations have also been carried out to determine the magnitude of the moment of rotation M_d and find its relation with the angular displacement φ of the central pipe for the sunflower seeds in each of the fractions (Fig. 10).

As is seen on the diagrams presented in Fig. 10, the maximum magnitude of the moment of rotation M_d that arises during the rotation of the central pipe is equal to 4,100 Nm for the heavy fraction, for the medium fraction – 2,700 Nm. The difference between the sunflower seed fractions in this parameter amounts to 32.5%. The said difference results in the different motion paths of the fractions under consideration.

Finally, the authors have carried out the PC-assisted numerical calculation of the power required for the performance of the work process of sunflower seed separation. In Fig. 11, the relations are shown for the power required for separating the seeds of the medium and heavy fractions.

As is seen on the diagrams presented in Fig. 11, the maximum power consumed by the pressure air for the respective alteration of the motion paths of seed particles in the heavy fraction amounts to only 11.5 W, in the medium fraction – 9.0 W, i.e. by 22% less. Hence, it is obvious that the power costs of the work process under study are essentially insignificant.

In order to verify the results obtained in the theoretical investigations, the authors have carried out the experimental research into the vibration and aspiration separation of sunflower seeds. For that purpose, an experimental unit has been manufactured. Its general view is shown in Fig. 12, the schematic model of the unit is presented in Fig. 13. The unit is an industrial prototype of the vibration and aspiration separator, which is equipped with the required instruments and sensors.

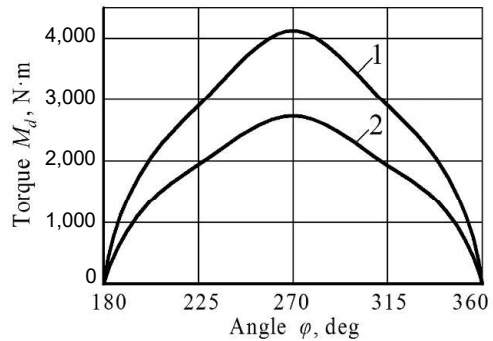

Figure 10. Relations between magnitude of moment of rotation M_d and angular displacement φ of central pipe for seeds in heavy (1) and medium (2) fractions, respectively.

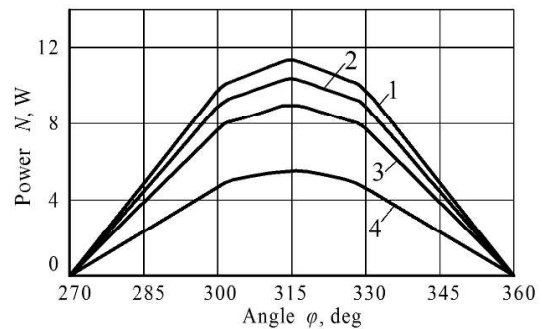

Figure 11. Relations between angular displacement φ of central pipe and maximum (1) and minimum (2) power consumption rates for heavy fraction seeds; maximum (3) and minimum (4) power consumption rates for medium fraction seeds, in process of generating self-oscillatory mode of operation.

The operating principle of the laboratory experimental unit is as follows. The grain mixture of sunflower seeds is fed from the feed hopper located above for its separation into fractions. In this process, the slide gate 5 makes up the batch of grain mixture with a pre-set mass and controls its feeding. The said grain mixture batch is fed by gravity via the shaped seed duct onto the top spreader of the central pipe situated in the fixed casing of the aspiration channel. The fan 3 generates the necessary induced air draught inside the fixed casing of the aspiration channel, the flow rate of which is controlled in the process of the experimental investigations by the instrument 2, while the instrument 4 registers the air velocity. Further, the process of vibration and aspiration sunflower seed separation into fractions, as described earlier, takes place, and the results of the process take shape and get fixed below on the horizontal surface 1. The surface 1, onto which the seeds of different (medium and heavy) fractions arrive and on which they get fixed, is a replaceable sheet of paper coated with an adhesive layer, which is fixed in a strictly set position with respect to the central pipe of the vibration and aspiration separator. After separating each pre-set size batch of sunflower seeds, the paper sheet is taken away in order to carry out the corresponding measurements of the displacement of seeds with respect to the central pipe and to weigh the seeds.

The operating principle of the laboratory experimental unit is as follows. The grain mixture of sunflower seeds is fed from the feed hopper located above for its separation into fractions. In this process, the slide gate 5 makes up the batch of grain mixture with a pre-set mass and controls its feeding. The said grain mixture batch is fed by gravity via the shaped seed duct onto the top spreader of the central pipe situated in the fixed casing of the aspiration



Figure 12. General view of experimental unit for research into vibration and aspiration separation of sunflower seeds.

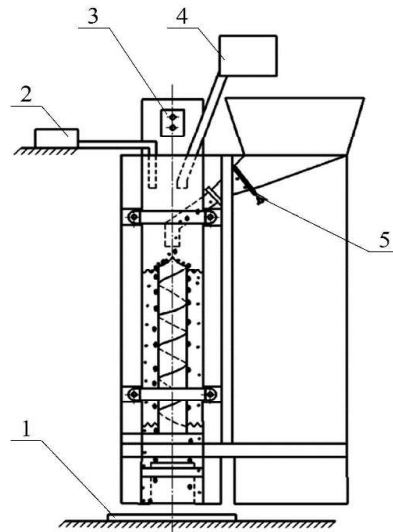

Figure 13. Schematic model of laboratory experimental unit for research into vibration and aspiration separation: 1 – surface, where different fraction seeds arrive and get fixed; 2 – instrument for measuring dynamic pressure of air; 3 – fan for generation of induced air draught; 4 – instrument for measuring air velocity; 5 – slide valve that controls feeding of batch of sunflower seeds.

channel. The fan 3 generates the necessary induced air draught inside the fixed casing of the aspiration channel, the flow rate of which is controlled in the process of the experimental investigations by the instrument 2, while the instrument 4 registers the air velocity. Further, the process of vibration and aspiration sunflower seed separation into fractions, as described earlier, takes place, and the results of the process take shape and get fixed below on the horizontal surface 1. The surface 1, onto which the seeds of different (medium and heavy) fractions arrive and on which they get fixed, is a replaceable sheet of paper coated with an adhesive layer, which is fixed in a strictly set position with respect to the central pipe of the vibration and aspiration separator. After separating each pre-set size batch of sunflower seeds, the paper sheet is taken away in order to carry out the corresponding measurements of the displacement of seeds with respect to the central pipe and to weigh the seeds.

Several sets of experimental investigations with the necessary numbers of test replications have been carried out in accordance with the specially developed programme and technique of a multifactorial experiment and following the respective setup and adjustment of the laboratory unit. The necessary measurements and the weighing of the separated fractions have been performed and their results have been processed on the PC with the use of statistical methods.

As is seen from the presented graphic relations plotted on the basis of the results of the experimental investigations, the motion paths of sunflower seeds depend to a great extent on the masses of the seeds and the velocity of the air flow (Fig. 14).

As can be seen from the presented graphs, the heavy fraction sunflower seeds land virtually in the immediate vicinity of the outer generating line of the central pipe in the aspiration channel, having traversed the shortest distances.

If the theoretically derived distances traversed by the heavy fraction seeds (Fig. 6) are compared to the similar distances obtained as a result of the experimental research (Fig. 14), it becomes obvious that there is a virtually complete agreement with regard to this criterion between the theoretical and experimental results, because in both cases the said distance does not exceed 40 mm. At the same time, the most efficient sunflower seed separation takes place at an air flow velocity of 4.0 m s^{-1} . When the mentioned velocity is increased, the share of the low quality light fraction sunflower seeds (where good quality medium fraction seeds can get as well) carried away together with the air flow beyond the limits of the separator also increases.

The same agreement between the results of the theoretical and experimental investigations is observed in case of the medium fraction sunflower seeds, which are deposited at a greater distances from the central pipe of the aspiration separator.

Thus, when the design and kinematic parameters obtained theoretically are used in the operation of the laboratory and industrial unit, the vibration and aspiration separator

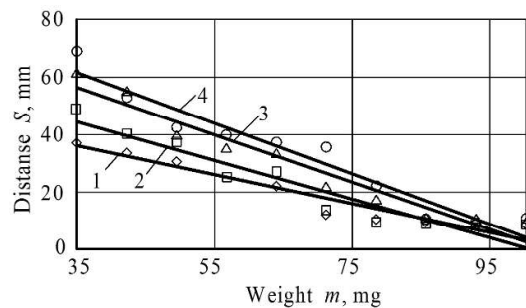

Figure 14. Relation between distance traversed by sunflower seed relative to outer surface of vertical pipe and its mass at different air flow velocities: 1) 4.0 m s^{-1} ; 2) 4.5 m s^{-1} ; 3) 5.0 m s^{-1} ; 4) 5.5 m s^{-1} .

demonstrates stable performance providing guaranteed separation of sunflower seeds into the above-mentioned fractions.

CONCLUSIONS

1. The authors have developed a new theory of the motion of a grain mixture particle, i.e. a mathematical model has been generated for describing the motion of a material particle (seed) in the operating space of the vertical aspiration channel of new design under the action of the air flow forces and the centrifugal forces of inertia generated by the angular self-oscillations of the separator's central pipe.

2. Analytical solutions have been obtained for the differential equations of motion of the material particle that represent the laws of motion and variation of velocity and acceleration in time in relation to the design and dynamic parameters of the vibration and aspiration separator.

3. The numerical calculations have indicated a significant difference between the distances covered by the seeds of the medium and heavy fractions. For example, for the central pipe's angular displacement within the range of 200° – 335° the said difference amounts to 20–40 mm. That proves the high quality of the separation of seeds into fractions under the action of the centrifugal forces of inertia generated by the oscillating central pipe of the separator.

4. The difference in the velocities of the motion of particles in the cross-section of the central part of the aspiration channel is equal to 0.6 – 1.5 m s⁻¹, the difference in the accelerations is equal to 0.7 – 1.4 m s⁻².

5. The numerical calculations have also indicated that the maximum magnitude of the perturbing force acting on seeds in the heavy and medium fractions is equal to 100 N and 68 N, respectively, the difference between these values reaching 32%. The maximum magnitude of the rotation moment for the heavy fraction seeds is equal to 4100 Nm, for the medium fraction seeds – 2,700 Nm, the difference between different sunflower seed fractions amounting to 32.5%. The said differences are exactly what causes the fractions under research to move on different motion paths.

6. The maximum power consumed by the pressure air for changing the motion paths of the heavy fraction particles as described amounts to 11.5 W, in case of the medium fraction – 9.0 W, i.e. 22% less. Therefore, the completed analysis has proved that the power consumption in the performance of the researched work process is rather insignificant.

7. The obtained theoretical results have provided a possibility to substantiate a number of design and kinematic parameters for the vibration and aspiration separator: diameter of the seed duct for the medium fraction – within the range of 50–70 mm, the heavy fraction – 90–110 mm; diameter of the separator's central pipe – 200 mm; air flow velocity – 4.5–5.5 m s⁻¹; angular velocity of rotation of the central pipe in its self-oscillatory motions – 50 s⁻¹.

8. The results of the completed experimental investigations fully confirm the validity of the developed theory.

REFERENCES

- Badretidinov, I., Mudarisov, S., Tuktarov, M., Dick, E. & Arslanbekova, S. 2019. Mathematical modelling of the grain material separation in the pneumatic system of the grain cleaning machine. *Journal of Applied Engineering Science* **17**(4), 529–534. doi: 10.5937/jaes17-22640
- Bernik, P.S. & Palamarchuk, I.P. 1996. *Conveyor vibration machines for finishing and handling treatment*. Kiev, Vöshaja škola, 237 pp.
- Brăcăcescu, C., Pirna, I., Sorica, C., Popescu, S. & Stan, O. 2012. Experimental research on influence of functional parameters of gravity separator on quality indicators of separation process with application on cleaning of wheat seeds. *Engineering for Rural Development* **11**, 16–21.
- Brăcăcescu, C., Tenu, I., Mircea, C. & Bunduchi, G. 2019. Experimental research on influence of functional parameters of combined installations designed at separating the impurities out of cereal seeds. *E35 Web of Conferences, 8th Int. Conf. on Thermal Equipment, Renewable Energy and Rural Development*. Vol. 112, Article no 03004, doi: 10.1051/e3sconf/201911203004
- Burkov, A.I. 1991. *Research into work process of closed pneumatic system in seed-cleaning machine*. Thesis for degree of Candidate of Sciences. Kirov, 217 pp.
- Kotov, V.V. 2002. Determining velocity of grain in air flow. *Technologies and Mechanical Means in Field Husbandry*, Zernograd, pp. 137–140.
- Kroulik, M., Hula, J. & Rybka, A. 2016. Pneumatic conveying characteristics of seeds in a vertical ascending airstream. *Research in Agricultural Engineering* **62**(2), 56–63.
- Kyurchev, S.V. & Kolodiy, A.S. 2012. Analysis of methods to improve agricultural crop capacity and requirements to separated material. In: *Proceedings of Scientific Papers*, Vinnitsa National Agrarian University, **11**(2), 322–327.
- Kyurchev, S.V. & Kolodiy, A.S. 2015. Multi-criterion analysis of existing seed separators with different operating devices. In: *Bulletin of Kharkiv National Technical University of Agriculture* **156**(1), 86–92.
- Leshchenko, S.M., Vasilkovsky, A.N., Vasilkovsky, M.I. & Gontšarov, V.V. 2009. Raising efficiency of pre-treatment of grain mixtures. In: *Agricultural Machinery*, Lutsk, **18**, 230–234.
- Poturayev, V.N. & Franchuk, V.P. 1970 *Selected theoretical prerequisites for research into mechanics of motion of thick loose load layer under the action of vibration*. Kiev: Naukova Dumka, pp. 173–181.
- Saitov, V.E., Farafanov, V.G., Gataullin, R.G. & Saitov, A.V. 2018. Research of a diametrical fan with suction channel. *IOP Conf. Series: Materials Science and Engineering* **457**, 6 pp. doi: 10.1088/1757-899X/457/012009
- Saitov, V.E., Kurbanov, R.F. & Suvorov, A.N. 2016. Assessing the Adequacy of Mathematical Models of Light Impurity Fractionation in Sedimentary Chambers of Grain Cleaning Machines. *Procedia Engineering* **150**, 107–110. doi: 10.1016/j.proeng.2016.06.728
- Vasilkovsky, M.I., Goncharova, S.J. & Leshchenko, S.M. 2007. Substantiation of parameters for grain separation in inclined air flow. Design, Production and Operation of Agricultural Machines: *Nationwide Interagency Research and Technology Collected Papers*. Kirovograd National Technical University, Kirovograd, **37**, 132–137.