

Justification of parameters for novel rotary potato harvesting machine

V. Bulgakov¹, V. Bonchik², I. Holovach¹, I. Fedosiy¹, V. Volskiy³, V. Melnik⁴,
Ye. Ihnatiev⁵ and J. Olt^{6,*}

¹National University of Life and Environmental Sciences of Ukraine, 15 Heroyiv Oborony Str., UA 03041 Kyiv, Ukraine

²State Agrarian and Engineering University in Podilia, 13 Shevchenko Str., UA 32300 Kamenets-Podilsky, Ukraine

³National Scientific Centre, “Institute for Agricultural Engineering and Electrification”, 11 Vokzalna Str., Glevakcha 1, Vasylkiv District, UA 08631 Kyiv Region, Ukraine

⁴Kharkiv Petro Vasylenko National Technical University of Agriculture, 44 Alchevskih Str., UA 61002 Kharkiv, Ukraine

⁵Dmytro Motornyi Tavria State Agrotechnological University, 18^B Khmelnytsky Ave, UA 72310 Melitopol, Zaporozhye Region, Ukraine

⁶Estonian University of Life Sciences, Institute of Technology, 56 Kreutzwaldi Str., EE 51006 Tartu, Estonia

*Correspondence: jyri.olt@emu.ee

Received: March 6th, 2021; Accepted: May 12th, 2021; Published: May 14th, 2021

Abstract. The authors have set an aim in relation to the development of a novel rotary potato harvesting machine design and the substantiation of rational design and process parameters for the clod crushing tools in the machine in order to improve its separation capacity. A novel design solution has been suggested for the process of crushing the two adjacent potato rows with the vanes of the vertical rotor and the expediency of using the methods of crushing clods in the two adjacent potato rows in advance has been justified. Also, the more rational placement of the clod crushing tools in the potato harvesting machine has been suggested. Following the completed research, the geometrical parameters of the vertical rotor have been substantiated, in particular, its diameter $d_p = 0.65\text{--}1.0$ m and height $h_{zag} = 0.27$ m. Additionally, the process parameters have been substantiated for some other tools crushing the clods, in particular, the angle of inclination of the share’s working face, which has to be equal to 10° , the elevator belt width $b_{cl} = 1.05$ m, the linear velocity of the belt $V_p = 1.95$ m s⁻¹, the belt agitation amplitude $A_{st} = 18$ mm. If the soil moisture content is equal to $W = 18.4\%$, the soil separation rate rises insignificantly, when the rotor diameter increases within the range of $0.65\text{--}1.0$ m, moreover, at $V_m = 1.0$ m s⁻¹ it varies within the range of $85.3\text{--}87.2\%$, at $V_m = 1.5$ m s⁻¹ – within the range of $87.0\text{--}92.7\%$, at $V_m = 2.0$ m s⁻¹ – within the range of $86.0\text{--}89.1\%$. The best performance is achieved at a rotor rotation frequency of $n_p = 100$ min⁻¹ and a translational velocity of $V_m = 1.5$ m s⁻¹, in which case the soil separation rate S is equal to 93.5% . The tuber damage rate P_b decreases from 4.2% to 1.5% , as the rotor diameter d_p increases from 0.65 m to 1.0 m, the translational velocity of the machine V_m – from 0.8 to 2.2 m s⁻¹ at the rotor rotation frequency $n_p = 50\text{--}100$ min⁻¹.

Key words: clod-crushing, harvesting machine, loamy soil, potato, soil separation, vertical rotor.

INTRODUCTION

In the potato production process, the harvesting is one of the most complicated and power consuming process operations (Peters, 1997; Gao et al., 2011; Xin & Liang, 2017; Issa et al. 2020). The quality of its performance has a significant effect on the labour intensity of the further operations and the shelf life of the output product (Gulati & Singh, 2019). In contrast to many other crops, the potato harvesting presumes lifting a soil slice of a considerable volume and extracting potato tubers from it, reaching a cleanness rate of at least 80% and a damage rate of not more than 3% in the combine harvester's hopper. (Wang et al., 2017; Bulgakov et al., 2018a, 2018b, 2018c; Wei et al., 2019a, 2019b).

In case potatoes are cultivated on heavy loam soil prone to compaction during its cultivation, by the time of harvesting, when the potato harvester lifts tuber-bearing soil slices, a significant amount of clods is formed, which cannot be removed by the combine harvester's separating tools (Kheiry et al., 2018; Pshechenkov et al., 2018; Bulgakov et al., 2019).

In that case, the soil content in the potato heap conveyed to the hopper exceeds 20%, which is not in compliance with the agronomical requirements. That is the reason, why well-known potato combine harvesters can operate only on sandy soils, sandy-loam and medium grain-size composition soils with optimum moisture contents. On heavy loam soils the potato heap cleanness rate does not rise above 55–74%, while the tuber damage rate is at a level of 18–25% (Lü et al., 2015 and 2017).

That complicates the processing of the potato heap, as agricultural companies face the need to apply manual labour widely in harvesting operations, which significantly raises the production cost of the final product. All the preparatory work prior to harvesting potatoes have to target loosening the structure of the tuber-bearing bed, removing hard clods from it and establishing the conditions that would provide for considerably reducing the amount of the soil impurities sized similarly to potato tubers that enter the separating tools of the potato harvester. Fulfilling the above-mentioned conditions will provide for increasing the efficiency of combine harvester operation on heavy soils and reducing the potato tuber loss and damage rates.

In the analysis of the interaction between the clod breaking tools and the tuber-bearing soil bed of the potato row, special consideration is given to the clod disintegration under the conditions of dynamic loading. According to the study by Petrov (2004), it has been established that, in order to break 98% of the clods in heavy loam soil, it is necessary to provide an impact velocity of 5.5 m s^{-1} during their collision with the metal surface, which is equivalent to a free fall from a height of 1.5 m. In that case, the tuber damage rate is equal to 69.9%. It should be noted that the tuber damage rate does not exceed the permissible level in case of a free fall from a height of 0.25 m, when it is equal to 13%. According to the data by Matzepuro (1979) and Blahovec & Židova (2004), this distance of fall provides for breaking only 8.3% of the clods, which does not meet the harvester adequate performance standards.

Following these studies, similar research was undertaken into the case of the tuber and soil clod colliding with the surface of a riddle chain. At the same time, it was suggested that the dynamic fracture of the clod could take place at the beginning of the work process, i.e. within the zone of lifting the tuber-bearing soil slice and transferring it onto the riddle chain, where the large amount of soil reliably protected the tubers against mechanical damage (Vasilenko, 1998).

The choice of the mechanical aids for harvesting potatoes is defined, first of all, by the specific farming conditions: type and moisture content of the soil, size and terrain of the field, presence of stone and plant debris in the field, yielding capacity of the variety etc. For example, it is inexpedient to apply potato harvesters in small fields with higher moisture contents of up to 20%. Potato lifters are more appropriate in such cases.

As is known, the operation of state-of-the-art potato harvesters in conditions of heavy loam soils features the unsatisfactory, sometimes even impossible separation of the potato bed components and a high degree of tuber damage (Brook, 1993).

In order to eliminate the above-mentioned deficiencies, researchers attempt to develop and improve the machine designs by means of introducing combined clod breaking tools into the work process.

The studies by many authors (Matzepuro, 1979; Feller et al., 1987; Misener & McLeod (1989, 1996); Vasilenko, 1996; Peters, 1997; Petrov, 2004; Ruyschaert et al., 2006; Bishop, 2012; Ichiki et al., 2013; Feng et al., 2017; Wei et al., 2017; Nowak et al., 2019; Sibirev et al. (2019); Ruzhylo et al., 2020) have established that the disintegration of clods in a potato bed with the use of a dynamic load is more efficient than the disintegration by a static load and requires an 8 times smaller power input. It has also been proved that the soil clod has to be broken at the initial phase of the work process, that is, in the time of lifting the tuber-bearing soil slice, thus considerably lowering the load on the harvester's separating tools and increasing the separation rate, while the tubers are partially protected from mechanical damage in such a scenario.

In view of the above-mentioned methods of lifting tubers and the implementation of new designs in the development of tools for breaking clods in potato beds, a need arises to develop the process schematic model of the rotary potato harvester.

In the development of the new design of the potato harvester for heavy loam soils, the following standard agronomical specifications have been taken into account: the tuber lifting completeness is to be equal to at least 95%, while the tuber damage rate may not exceed 3% (Hevko et al., 2016). Also, when using a rotary clod breaking tool in the process schematic model of the machine, it is necessary to take into account the degree of soil separation in the riddle chain, which has to be equal to at least 90% (Lovkis, 1991).

Taking into account the complicated nature of the tuber lifting work process in view of the significant soil moisture content gradients and the contamination level in the fields, where the ridge planting method is applied and the row spacing width is equal to 70 cm, the design of the machine has to be developed individually for different types of farming units.

The aim of the study was to develop the design and substantiate the rational design and process parameters for clod breaking tools in the rotary-type potato harvester in order to improve its separating capacity.

MATERIALS AND METHODS

On the basis of the completed geometrical parameter measurements with regard to the potato row and the positions of tuber-bearing pockets in the row as well as the results of research by Lovkis (1991) and Petrov (2004), the authors have calculated the design parameters of the machine.

Together with the above-mentioned assumptions with regard to the substantiation of the process schematic model for the operation of a potato harvester, the authors have proposed a new type of the rotary tool for breaking clods in the potato row at the beginning of the tuber lifting work process, which, in combination with the known clod breaking tools, will improve the separating capacity of the potato harvester.

Modelling. The proposed design of the new potato harvester comprises the following main components mounted on the single frame: two depth rollers 1, vertical rotor 2, two spherical discs 3, solid digging share 4, rattle chain 5 and carrier wheels 6. The rattle chain 5 is equipped with the agitating device 7 (Fig. 1).

In this potato harvester, the primary clod breaking tools are the vertical rotor 2 and the spherical discs 3, which have the greatest effect on the quality of operation.

The positioning of the components relative to each other, except for the clod crushing tools, is based on the known potato harvester designs in compliance with the existing agronomical requirements (Xin & Liang, 2017).

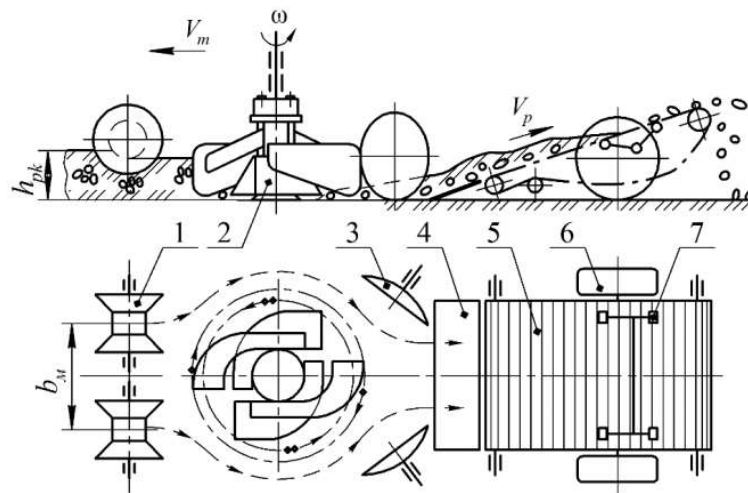

Figure 1. Process schematic model of rotary potato harvester operation: 1 – depth rollers; 2 – vertical rotor; 3 – spherical discs; 4 – lifting share; 5 – rattle chain; 6 – carrier wheels; 7 – elevator belt agitation device.

The vertical rotor (Fig. 2) comprises the following assembly units: shaft 8, planetary reduction gear 9, upper beater 10, lower beater 11, disc blade 12. In order to achieve the satisfactory disintegration of the two adjacent potato rows, the lower beater is equipped with cone-shaped vanes, the upper one - with cylinder-shaped vanes. The disc blade 12 is intended for ensuring the uniform penetration of the rotor's vanes as well as their smooth motion.

The potato harvester operates as follows. As the machine moves across the potato field prepared for the lifting operations, the depth rollers 1 roll along two planted rows. On the centreline of the inter-row spacing between the two adjacent potato rows, the vertical rotor 2 (Fig. 1) is situated. It has vanes on the upper 10 and lower 11 beaters (Fig. 2), which rotate in the directions opposite to each other shifting the two rows away from the centre of the inter-row spacing. The broken tuber-bearing bed is then shifted towards the centre of the inter-row spacing by the two spherical discs 3 which are positioned at a pre-set distance from the rotor's circumference at the angle of attack to

the machine's line of travel. After the disintegration, a windrow is formed, which is then collected by the solid share 4 and is additionally separated on the riddle chain 5 with the agitating device 7 (Fig. 1).

The described tools operate at the seating depth of the tuber-bearing pocket (up to 22 cm) with 3 cm variations (depending on the potato variety and the ridge height).

Hence, the proposed process schematic model of potato harvester operation is non-conventional comparing it to the commercially available machines, therefore, it has to be regarded as a rotary-type combined potato harvester.

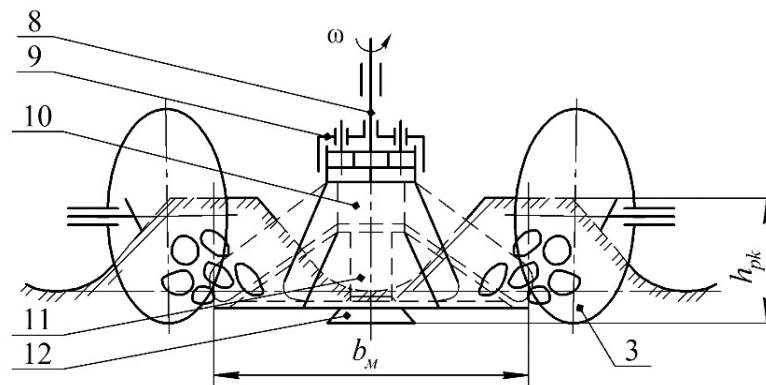

Figure 2. Schematic model of relative position of vertical rotor and two spherical discs (front view).

Further, the stages in the disintegration of the two adjacent potato rows during the operation of the proposed potato harvester have to be examined in detail.

As can be seen in the process schematic model of the operation of the potato harvester under consideration, the process of breaking the two adjacent potato rows follows a certain sequence. Nevertheless, in order to substantiate the design and process parameters of the machine, it is necessary to know how the shape and dimensions of the tuber-bearing bed profile change after the tools pass it at the pre-set undercutting depth. In view of the fact that the process layout of the machine includes the known tool designs, the process of disintegration can be analysed basing on the known patterns of lifting. For example, in commercially available potato harvesters depth rollers are installed at the front in order to ensure that the machine travels along a straight line and to break partially the clods on the row surface. After that work, the tuber-bearing bed is undercut and lifted and disintegrated on the separating tools. Apart from applying the depth rollers, the authors have included into the work process the vertical rotor and the spherical discs, which have a task of initially breaking the two adjacent potato rows at the pre-set depth of undercutting. That operation is followed by the pickup of the broken rows.

Thus, taking into account the sequence, in which the tools are positioned in the process layout, it is possible to define the stages in the disintegration of the two adjacent potato rows (Fig. 3).

With the use of the presented schematic models (Fig. 3), the authors have calculated the distances, at which the tools have to be positioned with respect to each other, and also the depth of their travel in the soil.

In view of the fact that the proposed potato harvester process layout utilises the designs of commercially available units, the analysis has been done only with regard to the main parameters of the vertical rotor and its relative position with respect to the contiguous clod breaking tools.

In order to calculate the design and process parameters of the vertical rotor combined with the additional tools, it is necessary to take into account the geometrical dimensions of the potato row and the positioning of the tuber-bearing pockets as well as the physical and mechanical properties of the soil.

Basing on the results of the conducted analysis on the strength of the potato bed layers in case of medium loam soils, it has been concluded that the most intensive clod breaking has to take place in the lower layers of the bed. In order to reduce the tuber damage rate, the action of the tools on the tuber-bearing bed has to remain within the permissible limits of the impact force (Matzepuro, 1979).

Hence, the vanes of the vertical rotor have to produce the action that varies with the depth in the undercut tuber-bearing soil slice. That implies that the rotation speed of the vane ends on the lower beater must be greater in comparison to the upper one. In order to ensure smoother travelling and reduce the tuber damage rate, the working face of the lower beater vane has to be of a conical shape, the working face of the upper beater vane has to be shaped as a cylinder.

For determining the diameters of the upper and lower beaters in the rotor, it is necessary to have the parameters of the tuber-bearing pocket positioning in the row (Fig. 4).

According to the results of the completed research into the geometrical parameters of the potato row, it has been established that the maximum deviation of the tuber's position from the row centreline to the left is equal to 0.18 m, to the right - 0.16 m. The position of the deepest potato tuber is at a depth of 0.25 m, the uppermost one - 0.02 m (Bishop et al. 2012).

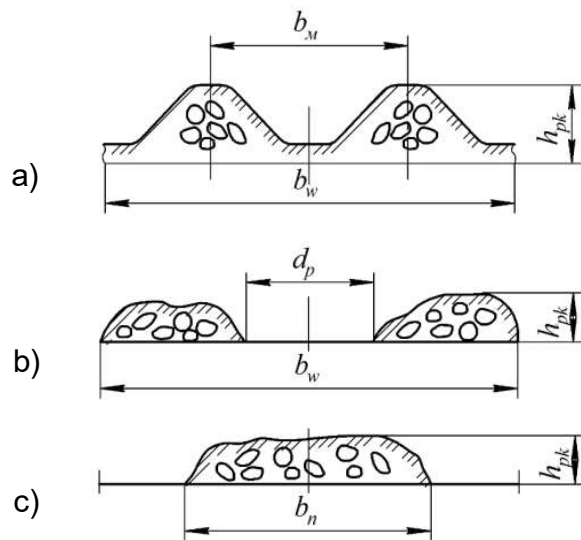

Figure 3. Stages in disintegration of two adjacent potato rows: a) depth rollers (stage I); b) vertical rotor (stage II); c) spherical discs (stage III): b_w – working width of machine; d_p – diameter of rotor; h_{pk} – height of row; b_n – width of windrow.

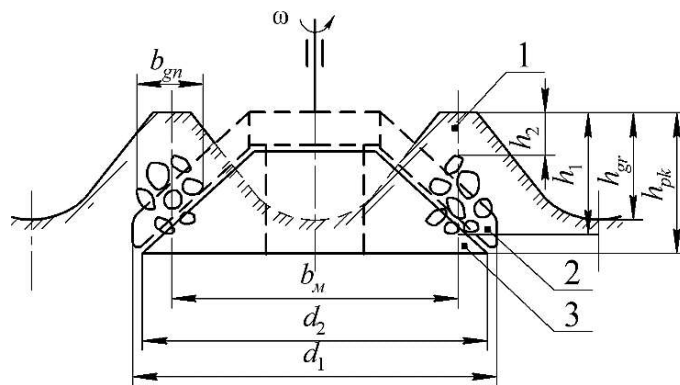

Figure 4. Layout diagram of vertical rotor situated between two adjacent potato rows: 1 – potato row; 2 – upper beater; 3 – lower beater.

Taking into account the results of the preliminary study completed by the authors, it is assumed that the width of the tuber-bearing pocket is $b_{gn} = 0.35$ m, while the depth, at which the lowermost potato tuber sits, is $h_1 = 0.25$ m.

In view of the fact that the upper beater is intended for breaking the upper ridge layers and changing the direction, in which the mass broken by the lower beater moves, its diameter must be greater than the lower beater diameter by 15–20 cm.

Taking into account the previously mentioned assumptions, the diameter d_1 of the upper beater is to be within the limits of the potato tuber position excursion from the row centreline, that is, 18 cm.

On the basis of the above-said, the upper beater diameter d_1 can be calculated with the use of the following formula:

$$d_1 = b_m + b_{gn}, \quad (1)$$

where b_m – inter-row spacing width, $b_m = 0.7$ m; b_{gn} – tuber-bearing pocket width, $b_{gn} = 0.35$ m. Hence, $d_1 = 1.05$ m.

The lower beater diameter d_2 can be determined basing on the following expression:

$$d_2 = b_m + \frac{b_{gn}}{2}, \quad (2)$$

hence, $d_2 = 0.875$ m.

The rotor diameter d_p is assumed to be in accordance with the upper beater diameter d_1 . That is: $d_p = d_1 = 1.05$ m.

Apart from the above calculations, it is necessary to determine the height of the rotor. In view of the design dimensions presented in the diagrams, the required height can be determined as follows:

$$h_{zag} = h_{nk} + h_2, \quad (3)$$

where h_{nk} – depth of undercutting, $h_{nk} = 0.25$ m; h_2 – uppermost tuber sitting depth, $h_2 = 0.02$ m.

The quality of the spherical discs' performance depends on the shape of the material tossed towards the inter-row spacing centreline. As the potato row material comprises various plant debris, tubers and soil, the inappropriate positioning of the discs with respect to the rotor's circumference can result in potato heap accumulation and tool plugging. Moreover, in order to ensure the satisfactory displacement of the broken mass, it is necessary to set the spherical discs at a pre-set angle to the machine's line of travel.

For the purpose of determining the above-mentioned parameters, the layout of the spherical discs with respect to the rotor's circumference in the horizontal plane has to be considered (Fig. 5).

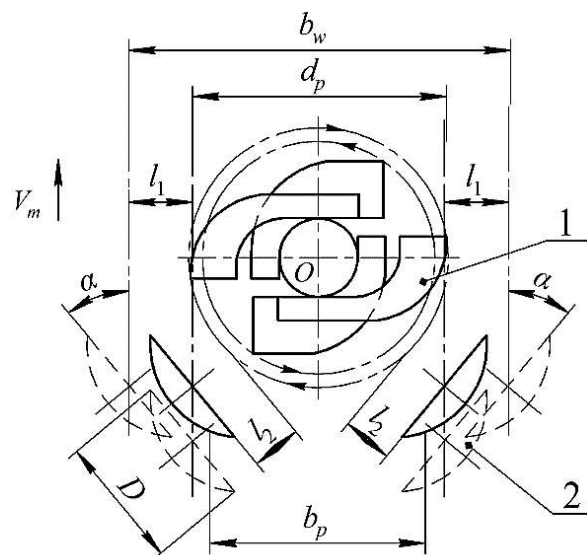

Figure 5. Layout diagram of vertical rotor and spherical discs in horizontal plane: 1 – vertical rotor; 2 – spherical disc.

For the known working width of the machine and rotor diameter, the distance, to which the broken tuber-bearing soil slice is displaced from the inter-row spacing centreline, is found as follows:

$$l_1 = \frac{1}{2}(b_w - d_p), \quad (4)$$

where b_w – machine's working width, $b_w = 1.4$ m, d_p – rotor diameter, $d_p = 1.05$ m. Hence, $l_1 = 0.175$ m

In order to calculate the distance, to which the broken tuber-bearing soil slice is displaced towards the inter-row spacing centreline, it is necessary to take into account the soil tossing distance, which in case of disc tools is equal to $L = 230\text{--}280$ mm at the depth of travelling in the soil $h = 14$ cm.

As the spherical discs in the potato harvester under consideration perform the work of forming a windrow, the following condition has to be fulfilled to ensure the satisfactory performance of the machine:

$$b_p < (b_w - 2l_1), \quad (5)$$

where b_p – width of the formed windrow (m).

Hence, $b_p < 1.05$ m.

Further, the distance between the rotor and the spherical discs is determined by the following expression:

$$l_2 = D \cdot \tan \alpha, \quad (6)$$

where D – diameter of a spherical disc (assumed $D = 0.45$ m); α – disc attack angle with respect to the potato harvester's line of travel (assumed $\alpha = 30^\circ$).

In order to calculate the design data of the primary clod breaking tools and their relative positions, it is necessary to select the parameters of the additional potato harvester tools, which comprise the depth rollers, the share and the riddle chain with the agitation device (Fig. 1).

Basing on the known potato harvester designs, some commercially available depth rollers can be taken and positioned for the operation with a planted potato inter-row spacing width of 70 cm. The distance between the rotor's circumference and the depth rollers l'' is assumed to be equal to 0.5 m. The solid digging share is installed behind the vertical rotor at a distance of $l''' = 0.5$ m. The share working width b_l is assumed to be equal to the windrow width, that is, to 1.05 m (Fig. 1). In order to ensure the satisfactory transportation of the tuber-bearing soil slice, the angle of inclination of the share's working face to the horizontal plane is assumed to be equal to 10° .

After the disintegrated tuber-bearing soil slice is collected by the solid share, it is transferred to the riddle chain with the agitating device. The elevator belt width b_{el} is assumed to be equal to 1.05 m (Fig. 1). The belt screening area is then equal to 1.5 m². The values of the belt's linear velocity and agitation amplitude are assumed proceeding from the parameters of commercially available potato harvesters, that is: $V_p = 1.91$ m s⁻¹, $A_{st} = 18$ mm.

The completed research provided the necessary material for the development of a new potato harvester with a rotary tool. During its farm testing, the new potato harvester proved to have a number of advantages as compared with commercially available

machines:

- soil separation rate was on the average equal to 95%, which was by 15% better than in case of commercially available units, the tuber damage rate was at a level of 3–5%, which was by 10% lower than in case of commercially available units;

- vertical rotor could be applied on all types of soil at a moisture content of 15–25%, while delivering satisfactory operating results also on soils loaded with stones to the extent of 3% of the total heap mass;

- high degree of soil disintegration by the vertical rotor enabled reducing the design dimensions and the number of separating tools as well as the steel intensity of the machine as a whole;

- it was proved that the proposed relative positions of the clod breaking and separating tools in the machine could be adopted as the basic layout.

Thus, the completed investigations have proved the validity of the proposed process schematic model of the rotary potato harvester. On the basis of that, the rational design and process parameters for the potato harvester layout design have been determined, as presented in Fig. 1 and in Table 1.

With the use of the numerical values of the machine's design and process parameters (Table 1), the authors have developed a new potato harvester design.

Experimental. For the research into the agronomical and power consumption performance of the new potato harvester, the authors have designed and produced a pilot machine (Fig. 6), with the use of which laboratory and field experiment investigations have been carried out.

Table 1. Main design and process parameters for rotary potato harvester layout design

Parameter	Value
Machine working width, b_w	1.4
Inter-row spacing width, b_m	0.7
Share working width, b_l	0.98
Elevator belt width, b_{el}	0.98
Rotor diameter, d_p	0.825
Rotor working height, h_{zag}	0.27
Distance between rotor's circumference and spherical discs, l_2	0.3
Distance between rotor's circumference and depth rollers, l''	0.5
Distance between rotor's circumference and share, l'''	0.5



Figure 6. Pilot machine during laboratory and field experiment investigations.

The experimental investigation of the rotary potato harvesting pilot machine was carried out in field conditions in the fields of the Olenevskoye Experimental Farm under the National Research Centre of Institute of Agricultural Engineering and Electrification.

In the first stage of the investigations, a number of trial experiments were carried out in order to determine the factors that had no significant effect on the performance of the work process (Brandt, 2014). While doing that, the factors had been established that should be considered the primary ones: machine's translational velocity V_m , rotor rotation frequency n , rotor diameter d_p , distance between the spherical discs and the rotor's circumference l_2 .

RESULTS AND DISCUSSION

The results of the following research experiments allowed to establish the levels and variation ranges of the above-mentioned factors. Also, the operating capacity of the pilot machine was verified under different operating conditions. On the basis of the obtained data, the graphic relations between the agronomical and power consumption performance and the above-mentioned factors were plotted (Fig. 7, 8, 9, 10, 11, 12).

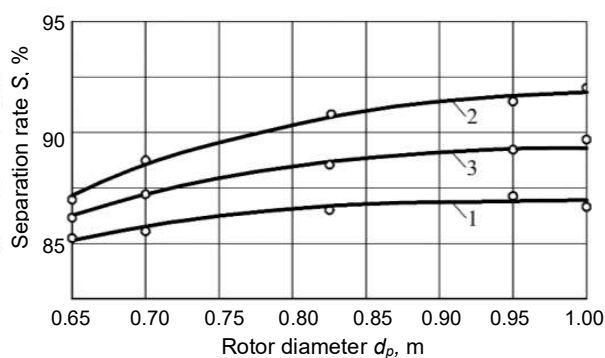

Figure 7. Relation between soil separation rate S and rotor diameter d_p at different translational velocities of machine V_m , at soil moisture content $W = 18.4\%$: 1) 1.0 m s^{-1} ; 2) 1.5 m s^{-1} ; 3) 2.0 m s^{-1} .

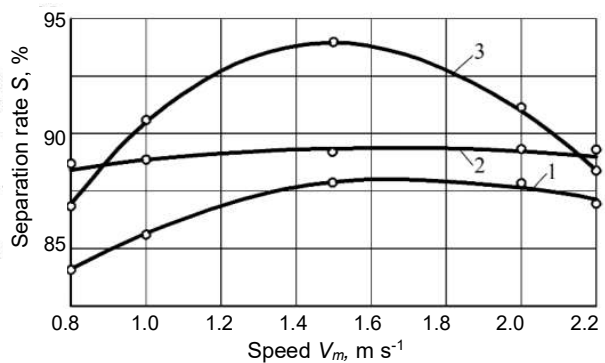

Figure 8. Relation between soil separation rate S and translational velocity of machine V_m at different rotor rotation frequencies n_p , at soil moisture content $W = 18.4\%$: 1) 50 min^{-1} ; 2) 80 min^{-1} ; 3) 100 min^{-1} .

The curves presented in Fig. 7 indicate the following: at a soil moisture content of $W = 18.4\%$ the soil separation rate improves insignificantly, as the rotor diameter increases within the range of 0.65–1.0 m, in particular, at $V_m = 1.0 \text{ m s}^{-1}$ it changes within the range of 85.3–87.2%, at $V_m = 1.5 \text{ m s}^{-1}$ – within the range of 87.0–92.7%, at $V_m = 2.0 \text{ m s}^{-1}$ – within the range of 86.0–89.1%. Changes in the machine's translational velocity have a more pronounced effect, which is obvious from the above-mentioned curves as well as the curves presented in Fig. 8. As the machine's translational velocity rises from 0.8 to 1.5 $\text{m}\cdot\text{s}^{-1}$, the separation rate increases, while in case of the machine's translational velocity rising within the range of 1.5–2.2 $\text{m}\cdot\text{s}^{-1}$ it decreases. The best performance has been achieved at a rotor rotation frequency of $n_p = 100 \text{ min}^{-1}$ and a

translational velocity of $V_m = 1.5 \text{ m}\cdot\text{s}^{-1}$, when the soil separation rate S becomes equal to 93.5% (Fig. 8). As the distance between the rotor's circumference and the spherical discs l_2 increases from 0.1 m to 0.5 m, the soil separation rate improves together with the growth of the translational velocity and varies within the range of 85.1–92.0% (Fig. 9).

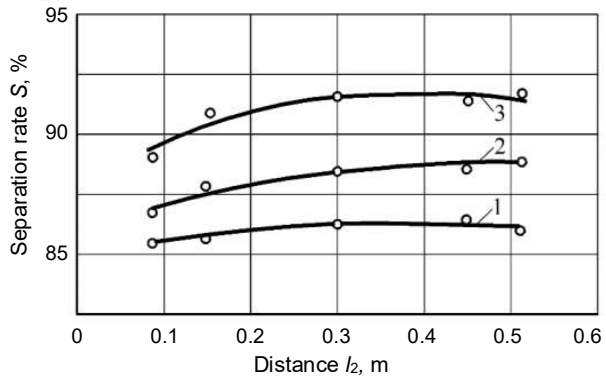

Figure 9. Relation between soil separation rate S and distance l_2 between rotor's circumference and spherical discs at different translational velocities of machine V_m , at soil moisture content $W = 18.4\%$: 1) $1.0 \text{ m}\cdot\text{s}^{-1}$; 2) $1.5 \text{ m}\cdot\text{s}^{-1}$; 3) $2.0 \text{ m}\cdot\text{s}^{-1}$.

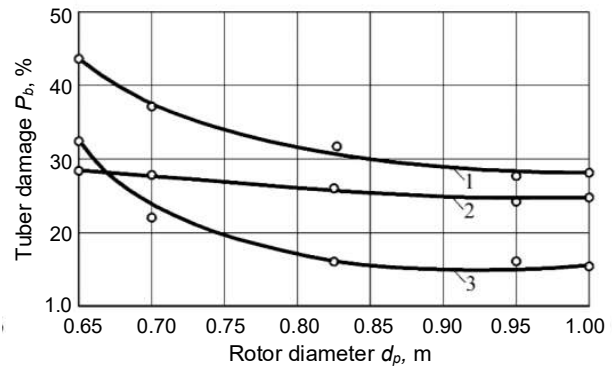

Figure 10. Relation between tuber damage rate P_b and rotor diameter d_p at different translational velocities of machine V_m , at soil moisture content $W = 18.4\%$: 1) $1.0 \text{ m}\cdot\text{s}^{-1}$; 2) $1.5 \text{ m}\cdot\text{s}^{-1}$; 3) $2.0 \text{ m}\cdot\text{s}^{-1}$.

The tuber damage rate P_b decreases from 4.2 to 1.5%, when the rotor diameter d_p increases from 0.65 m to 1.0 m and the machine's translational velocity V_m increases from 0.8 to $2.2 \text{ m}\cdot\text{s}^{-1}$ at the rotor rotation frequency $n_p = 50\text{--}100 \text{ min}^{-1}$ (Figs 10, 11). When the distance between the rotor's circumference and the spherical discs is increased, the tuber damage rate also rises (Fig. 12).

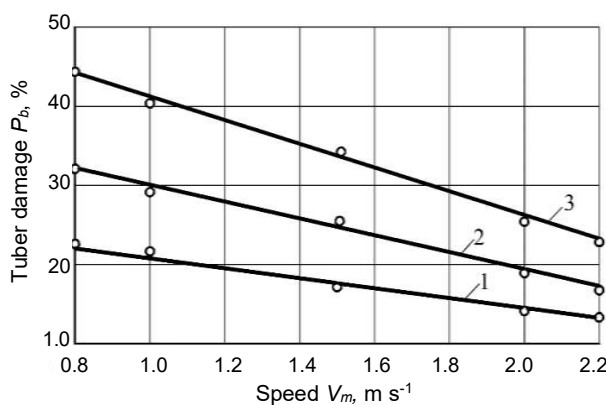

Figure 11. Relation between tuber damage rate P_b and translational velocity of machine V_m at different rotor rotation frequencies n_p , at soil moisture content $W = 18.4\%$: 1) 50 min^{-1} ; 2) 80 min^{-1} ; 3) 100 min^{-1} .

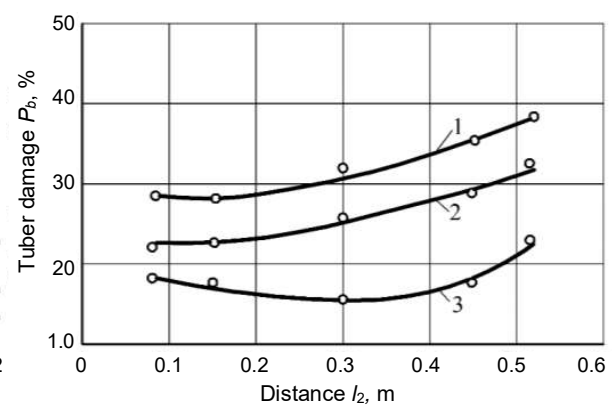

Figure 12. Relation between tuber damage rate P_b and distance l_2 between rotor's circumference and spherical discs at different translational velocities of machine V_m , at soil moisture content $W = 18.4\%$: 1) $1.0 \text{ m}\cdot\text{s}^{-1}$; 2) $1.5 \text{ m}\cdot\text{s}^{-1}$; 3) $2.0 \text{ m}\cdot\text{s}^{-1}$.

For the purpose of determining the quality performance, the soil clod size distribution in the two adjacent potato rows was analysed prior to and after the run of the pilot machine and the commercially available KST-1.4 potato lifter at a potato harvester translational velocity of $V_m = 1.5 \text{ m s}^{-1}$. The results of the analysis were used for plotting the diagram of the distribution of clods over the size fractions (Fig. 13). When the soil moisture content exceeded 25%, accumulation of the heap in front of the share and clogging of the tools were observed.

As is obvious from the diagrams (Fig. 13), the pilot machine developed by the authors disintegrates the soil bed significantly better than the commercially produced KST-1.4 potato lifter. That is, the soil clods are broken by the potato harvester of the proposed design on the average by 30% better than by the commercially produced machine.

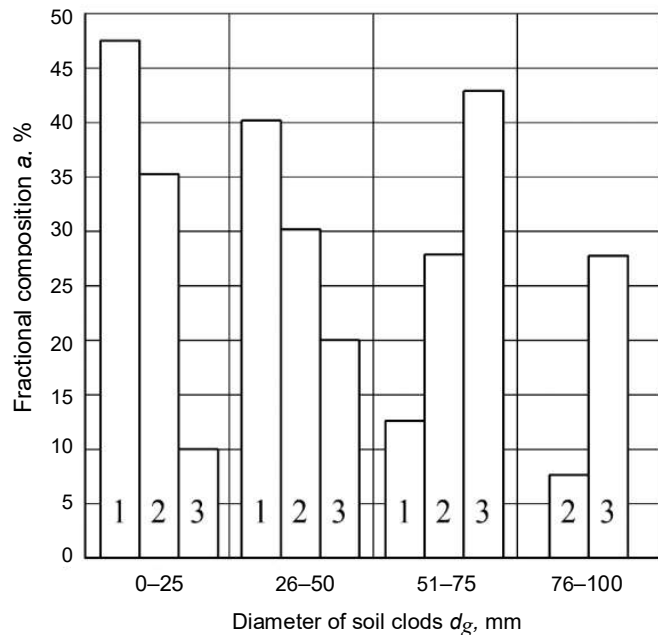

Figure 13. Clod size fraction distribution a in two adjacent potato rows: 1 – after run of pilot machine; 2 – after run of commercially produced KST-1,4 potato lifter; 3 – prior to run of pilot machine and commercially produced machine.

CONCLUSIONS

1. In order to improve the separation of soil on the riddle chain in the potato harvester, the new design of a rotary tool with a vertical rotation axis situated in the inter-row spacing of two adjacent potato rows and operating together with two spherical discs set at an attack angle of 30° with respect to the machine's line of travel has been proposed.

2. The following geometrical parameters of the vertical rotor have been theoretically substantiated: $d_p = 0.65\text{--}1.0 \text{ m}$, $h_{zag} = 0.27 \text{ m}$.

3. The following process parameters have been substantiated for the additional clod breaking tools: angle of inclination of the share's working face with respect to the horizontal plane equal to 10° , elevator belt width $b_{el} = 1.05 \text{ m}$, linear belt velocity $V_p = 1.95 \text{ m s}^{-1}$, belt agitation amplitude $A_{st} = 18 \text{ mm}$.

4. At a soil moisture content of $W = 18.4\%$, the soil separation rate increases insignificantly, when the rotor diameter increases within the range of $0.65\text{--}1.0 \text{ m}$, in particular, at $V_m = 1.0 \text{ m s}^{-1}$ it changes within the range of $85.3\text{--}87.2\%$, at $V_m = 1.5 \text{ m s}^{-1}$ – within the range of $87.0\text{--}92.7\%$, at $V_m = 2.0 \text{ m s}^{-1}$ – within the range of $86.0\text{--}89.1\%$.

5. The best performance has been achieved at a rotor rotation frequency of $n_p = 100 \text{ min}^{-1}$ and a translational velocity of $V_m = 1.5 \text{ m s}^{-1}$, when the soil separation rate S becomes equal to 93.5% .

6. The tuber damage rate P_b decreases from 4.2% to 1.5%, when the rotor diameter d_p increases from 0.65 m to 1.0 m and the potato harvester's translational velocity V_m increases from 0.8 to 2.2 m s⁻¹ at the rotor rotation frequency $n_p = 50\text{--}100 \text{ min}^{-1}$.

REFERENCES

- Bishop, C., Rees, D., Cheema, M.U.A., Harper, G. & Stroud, G. 2012. *Potatoes. Crop Post-Harvest: Science and Technology: Perishables*. Book Chapter, pp. 179–189.
- Blahovec, J. & Židova, J. 2004. Potato bruise spot sensitivity dependence on regimes of cultivation. *Research in Agricultural Engineering* **50**(3), 89–95. doi: 10.17221/4932.RAE.
- Brandt, S. 2014. *Data analysis: Statistical and computational methods for scientists and engineers*, eth ad., Springer International Publishing, 523 pp. doi: 10.1007/978-3-319-03762-2
- Brook, R.C. 1993. Impact testing of potato harvesting equipment. *American Potato Journal* **70**(3), 243–256.
- Bulgakov, V., Nikolaenko, S., Adamchuk, V., Ruzhylo, Z. & Olt, J. 2018a. Theory of retaining potato bodies during operation of spiral separator. *Agronomy Research* **16**(1), 41–51. doi: 10.15159/AR.18.036.
- Bulgakov, V., Nikolaenko, S., Adamchuk, V., Ruzhylo, Z. & Olt, J. 2018b. Theory of impact interaction between potato bodies and rebounding conveyor. *Agronomy Research* **16**(1), 52–64. doi: 10.15159/AR.18.037
- Bulgakov, V., Nikolaenko, S., Adamchuk, V., Ruzhylo, Z. & Olt, J. 2018c. Mathematical model of cleaning potatoes on surface of spiral separator. *Agronomy Research* **16**(4), 1590–1606. doi: 10.15159/AR.18.173
- Bulgakov, V., Pascuzzi, S., Nikolaenko, S., Santoro, F., Anifantis, A.S. & Olt, J. 2019. Theoretical study on sieving of potato heap elements in spiral separator. *Agronomy Research* **17**(1), 33–48. doi: 10.15159/AR.19.073
- Feller, R., Margolin, E., Hetzroni, A. & Galili, N. 1987. Impingement angle and product interference effects on clod separation. *Transactions of the American Society of Agricultural Engineers* **30**(2), 357–360.
- Feng, B., Sun, W., Shi, L., Sun, B., Zhang, T. & Wu, J. 2017. Determination of restitution coefficient of potato tubers collision in harvest and analysis of its influence factors. *Nongye Gongcheng Xuebao/Transactions of the Chinese society of agricultural engineering* **33**(13), 50–57.
- Gao, G., Zhang, D. & Liu, J. 2011. Design of a new soil-tuber separation device on potato harvesters. *CCTA 2010: Computer and Computing Technologies in Agriculture, IV*, 604–612. doi: 10.1007/978-3-642-18354-6_71
- Gulati, S. & Singh, M. 2019. Design and development of two row tractor operated potato combine harvester. *Potato Journal* **46**(1), 81–85.
- Hevko, R.B., Tkachenko, I.G., Synii, S.V. & Flonts, I.V. 2016. Development of design and investigation of operation process of small-scale root crop and potato harvesters. *INMATEH-Agricultural Engineering* **49**(2), 53–60.
- Ichiki, H., Nguyen Van, N. & Yoshinaga, K. 2013. Stone-clod separation and its application to potato in Hokkaido. *Engineering in Agriculture Environment and Food* **6**(2), 77–85.
- Issa, I.I.M., Zhang, Z., El-Kolaly, W., Yang, X. & Wang, H. 2020. Design, ansys analysis and performance evaluation of potato digger harvester. *International Agricultural Engineering Journal* **29**(1), 60–73.
- Kheiry, A.N.O., Elssir, A., Rahma, A.E., Mohamed, M.A., Omer, E.A., Gong, H.J. & Liwei, Y. 2018. Effect of operation variables of potato digger with double chain conveyors on crop handling and machine performance. *Int. J. of Environmental & Agricultural Research* **4**(6), 87–101.
- Lovkis, Z.V. 1991. *Intensive technology of growing potatoes in the Belarus*. Minsk, BelNIINTI, 84 pp.

- Lü, J.Q., Sun, H., Dui, H., Peng, M.M. & Yu, J.Y. 2017. Design and experiment on conveyor separation device of potato digger under heavy soil condition. *Transactions of the CSAM* **48**(11), 146–155 (in Chinese).
- Lü, J.Q., Tian, Z.E., Yang, Y., Shang, Q.Q. & Wu, J.E. 2015. Design and experimental analysis of 4U2A type double-row potato digger. *Transactions of the CSAE* **31**(6), 17–24 (in Chinese).
- Matzepuro, M.E. 1979. *Potato harvesting technologies*. Minsk, Belorussia, 301 pp.
- Misener, G.C. & McLeod, C.D. 1989. Resource efficient approach to potato-stone-clod separation. *AMA, Agricultural Mechanization in Asia, Africa and Latin America* **20**(2), 33–36.
- Misener, G.C. & McMillan, L.P. 1996. A belt-roller mechanism for soil clod reduction on potato harvester. *Canadian Agricultural Engineering* **38**(4), 311–314.
- Nowak, J., Bulgakov, V., Holovach, I., Olt, J., Arak, M., Ruzhylo, Z. & Nesvidomin, A. 2019. Oscillation theory of the free ends of the spiral separator for a potato heap. In: X International Scientific Symposium FMPMSA 2019: *Farm Machinery and Process Management in Sustainable Agriculture* 157–162. doi: 10.24326/fmpmsa.2019.1.
- Pshechenkov, K.A., Maltsev, S.V. & Smirnov, A.V. 2018. Technology of potatoes combine harvesting on loamy soils in the Central region of Russia. *Potato and Vegetables* **4**, 19–21 (in Russian).
- Peters, R. 1997. Damage of potato tubers: A Review. *Potato Research* **39**(Spec. Issue), 479–484.
- Petrov, G. 2004. *Potato harvesting machines*. Mashinostroeniye / Mechanical Engineering, Moscow, Russia, 320 pp. (in Russian).
- Ruyschaert, G., Poesen, J., Verstraeten, G. & Govers, G. 2006. Soil losses due to mechanized potato harvesting. *Soil & Tillage Research* **86**(1), 52–72. doi: 10.1016/j.still.2005.02.016.
- Ruzhylo, Z., Bulgakov, B., Adamchuk, V., Bondarchuk, A., Ihnatiev, Y., Krutyakova, V., Olt, J. 2020. Experimental research into impact of kinematic and design parameters of a spiral potato separator on quality of plant residues and soil separation. *Agraarteadus* **31**(2), 202–207. doi: 10.15159/jas.20.26.
- Siberev, A., Aksenov, A., Dorokhov, A. & Ponomarev, A. 2019. Comparative study of the force action of harvester work tools on potato tubers. *Research in Agricultural Engineering* **65**(3), 85–90. doi: 10.17221/96/2018-RAE
- Vasilenko, P.M. 1996. *Introduction to agricultural mechanics*. Kiev, Ukraine, Agricultural Education, 252 pp.
- Vasilenko, P.M. 1998. *The analytical method in soil mechanics*. Kiev, Ukraine, NAS, 28 pp.
- Wang, X., Sun, J., Xu, Y., Li, X. & Cheng, P. 2017. Design and experiment of potato cleaning and sorting machine. *Nongye Jixie Xuebao/Transactions of the Chinese Society for Agricultural Machinery* **48**(10), 316–322 and 279.
- Wei, Z., Li, X. & Sun, C. 2017. Analysis of potato mechanical damage in harvesting and cleaning and sorting storage. *Journal of Agricultural Science and Technology* **19**(8), 63–70. doi: 10.6041/j.issn.1000-1298.2019.01.014
- Wei, Z., Li, H., Sun, C., Li, X., Su, G. & Liu, W. 2019a. Design and Experiment of Potato Combined Harvester Based on Multi-stage Separation Technology. *Nongye Jixie Xuebao/Transactions of the Chinese Society for Agricultural Machinery* **50**(1), 129–140. doi: 10.6041/j.jssn.1000-1298.2019.01.014
- Wei, Z., Li, H., Sun, C., Su, G., Liu, W. & Li, Z. 2019b. Experiments and analysis of a conveying device for soil separation and clod-crushing for a potato harvester. *Applied Engineering in Agriculture* **35**(6), 987–996. doi: 10.13031/aea.13283
- Xin, L. & Liang, J. 2017. Design of potato harvester. *Journal of Mechanical Engineering Research and Developments* **40**(2), 380–384.