

Forced convection in drying of poultry manure

A. Aboltins^{1,*} and P. Kic²

¹Latvia University of Agriculture, Institute of Agricultural Machinery, Cakstes blvd. 5, Jelgava, LV–3001, Latvia; *Correspondence: aivars.aboltins@inbox.lv

²Czech University of Life Sciences Prague, Faculty of Engineering, Kamycka 129, 165 21, Prague 6, Czech Republic

Abstract. Pollution of environment by animal waste can be problem of intensive animal production in many countries with high density of animal farms. The aim of this paper is to inform about the experimental and theoretical investigations of moisture content reduction from poultry manure by forced convection. The experimental data created the background for calculation and modelling, which resulted in definition of the theoretical drying coefficient, useful for description and modelling of the drying process. The theoretical model has been verified and compared with experimental results obtained from the measurement. The laboratory equipment was used for test the forced convective drying of poultry manure due to vertical air streams going from bottom through supporting trays with holes and therefore through the manure up. Changed opened area of trays with different density has been used for definition of main parameters, which can serve especially in designing and construction of the new equipment for housing of poultry or improvement of the use of drying tunnel or in similar applications. The experimental data show that the air flow significantly increase the amount of moisture carried away from the material. Holes' size does not significantly affect water runoff by convection without additional air flow.

Key words: air, bottom drying, drying coefficient, model, moisture.

INTRODUCTION

The great problem of intensive animal production, especially in the countries with high density of population and also with high density of animal farms, is the animal waste management. Pollution of the environment by the animal waste can be a big problem which should be solved in the whole production and logistic chain. Modern farms with eggs production are typical with large capacity and concentration of laying hens in one location, which enable the use of industrial principles of technology but with respect to the animal welfare (Council Directive, 1999/74/EC).

Poultry manure can be a valuable resource of a significant amount of nitrogen, phosphorus, and many other components. The rapid growth of the animal breeding including the poultry industry in recent years and the application of waste to the agricultural land has resulted in excessive concentration of farms in many locations. Therefore direct fertilizing using fresh excrements is strictly limited by its consistence which does not allow a uniform spreading. Another limitation is the seasonality of application – it can be used only in a specific time-frame and is limited by the quantity (De Gobbi et al., 2012).

An application without treatment or non-appropriate disposal can become risky for environment and humans as such application might lead to the spread of diseases and may pollute soil and groundwater. Therefore the strong attention is paid to the technical solutions in the areas with intensive animal production (Chiumenti et al., 1993).

One of the reasonable solutions can be drying and reduction of water content in the manure, which can help to the solution of environmental problems and also reduce the costs of the logistics, storage and application for the farmers. Different technical principles of drying systems for poultry manure were used during the previous years. The producers of technological equipment for poultry usually apply the practical and empirical experience for the construction of drying equipment. The main principals are described in the literature, e.g. (Chiumenti, 2004). The investigations of characteristics of drying process of poultry manure at various temperatures have been done at the Faculty of Engineering CULS Prague (Liska & Kic, 2011).

In order to understand the drying process and find optimal drying regime it is necessary to understand transport mechanisms which take place within and on the surface of the product. Drying process is characterized by the existence of transport mechanisms such as surface diffusion, pure diffusion, capillary flow, evaporation, thermo-diffusion, etc. There are many different applications of drying for the agricultural (Jokiniemi et al., 2012; Aboltins & Palabinskis, 2013; Jokiniemi et al., 2014) or energetic purposes (Pasila, 2013). The forced convective drying of poultry manure by two air velocities going from tube to surface of trays with manure is given at (Kic & Aboltins, 2013).

The aim of this work is to bring some new experimental and theoretical investigations of drying of poultry manure with forced convective drying by air streams going from bottom through trays with different size of holes and therefore through manure up.

MATERIALS AND METHODS

The laboratory measurements were carried out at the Faculty of Engineering CULS Prague during weather conditions from July to September. The technical equipment used for the experiments was forced convection system (Fig. 1) (Kic & Liska, 2012), simulating partly the real technical system used in some drying tunnels with belt conveyer (Fig. 2) for drying in the poultry farms.

The moisture content in the manure was identified by gravimetric measurement in regular time intervals. Samples were weighed on the digital laboratory balance KERN-440-35N with maximum load weight 400 g and with resolution 0.01 g. The total drying time was adapted to the need for a determination of final moisture content.

Samples were weighted during the drying on a laboratory balance (Fig. 3) and values were recorded. Each measuring tray was weighed during the first 3 hours every 15 min, later during the next 2.5 hours every 30 min and after that every 60 min. To research the drying kinetics manure samples were placed on trays with three different hole sizes (3, 4, 5 mm) and sieve with mesh 3 x 4 mm.

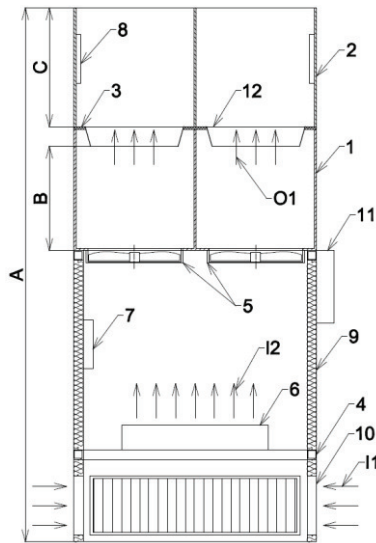

Figure 1. Apparatus used for manure drying (Kic & Liska, 2012): 1 – lower drying chamber; 2 – upper drying chamber; 3 – underlay; 4 – structure; 5 – fans; 6 – air heating; 7 – sensors; 8 – sensors; 9 – thermal insulation; 10 – inlet air; 11 – control panel; 12 – perforated tray with measured manure; I1 – inlet of fresh air; O1 – air passing through perforated tray with measured manure; A – overall height; B – height of the lower chamber; C – height of the upper chamber.

Air speed was measured by anemometer CFM 8901 Master with resolution 0.01 m s^{-1} and accuracy $\pm 2\%$ of final value. Air temperature and humidity was measured by the sensor FHA646-E1C connected to the data logger ALMEMO 2690-8.

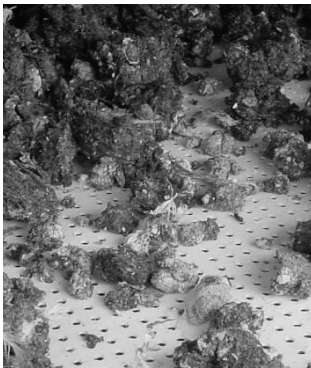

Figure 2. Manure on the bell.



Figure 3. Measuring plates in experiment.

Assuming that the product is placed in thin porous layer it can be considered that the manure moisture W depends only on the drying time (at constant drying temperature). Taking into account the mathematical model of drying process of porous material layer (Aboltins, 2013) the manure drying process can be described by mathematical expression:

$$\frac{dW}{dt} = K(t) \cdot (W_p - W) \quad \text{with condition } W(0) = W_s \quad (1)$$

where: W_s – manure moisture at the beginning of the experiment; %; W_p – equilibrium moisture content; dry basis, %; $K(t)$ – drying coefficient, h^{-1} .

Lack of knowledge of drying coefficient $K(t)$ makes difficult the drying process modelling. The $K(t)$ expression depends not only on the drying product but also the drying temperature and conditions. In addition, the drying rate is variable during the drying due to different mechanisms of a moisture transport such as a surface diffusion, pure diffusion, capillary flow, evaporation, thermo-diffusion, etc. There is used the common transport coefficient $K(t)$, which was found by the methodology (Aboltins, 2013).

RESULTS AND DISCUSSION

The kinetics of manure drying process caused by forced convection was measured by manure samples placed on trays with three different hole sizes (3, 4, 5 mm) and sieve with mesh 3 x 4 mm with the air speeds 1.13 m s^{-1} and 2.05 m s^{-1} . The results were compared with not forced drying.

Experimental results showed that the holes size does not significantly affect the water removal process from manure. The most significant acceleration of the drying process was observed through a sieve especially at higher air speeds (Figs 4, 5). Average air temperature during the drying process was $21.9 \text{ }^\circ\text{C}$.

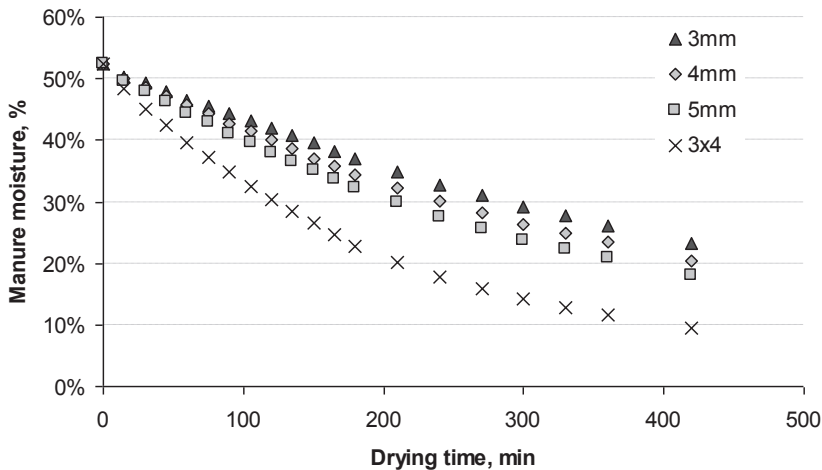

Figure 4. Moisture changes of manure samples placed on trays with different sizes of holes, by forced convection with air speed at bottom 2.05 m s^{-1} .

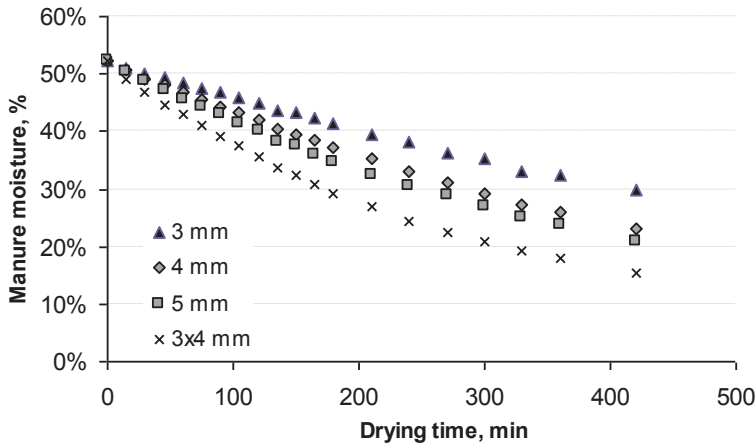

Figure 5. Moisture changes of the manure placed on trays with different sizes of holes, by the forced convection with the air speed at bottom 1.13 m s^{-1} .

It can be explained by the greater surface area of the manure through which is passing the air flow. Comparing the effects of air velocity, it can be seen that the higher air speed significantly increases the speed of drying at the beginning of the drying process. This can be explained by the migration of moisture from the surface of the product. Later, when the water runoff provides diffusion, the effect of air velocity on the product drying rate decreases.

The air flow velocity significantly affects the amount of water carried away, especially during the first 2–3 hours of drying (Figs 6, 7). During the first 3 hours of drying with all perforation holes and with the air speed 2.04 m s^{-1} is removed by 5% more moisture than with the air speed of 1.13 m s^{-1} . After 3 hours of drying on the sieve tray with the air velocity 2.04 m s^{-1} manure moisture is reduced to 22.7%.

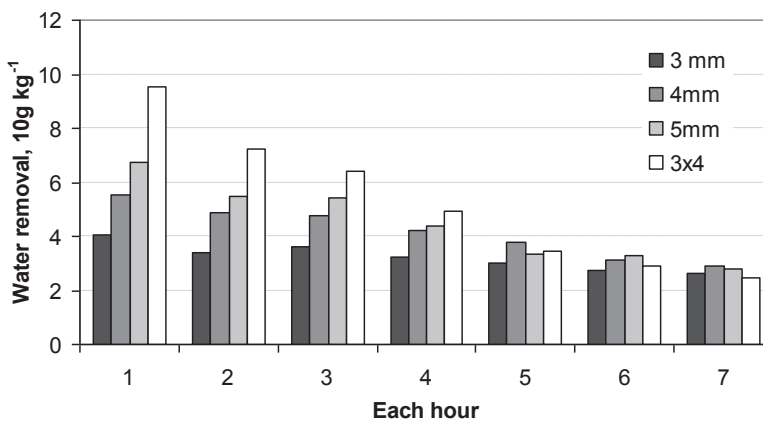

Figure 6. The moisture removal from the manure (10 g kg^{-1}) with the initial manure moisture 52.4%, at each hour of drying with the air speed at bottom 1.13 m s^{-1} .

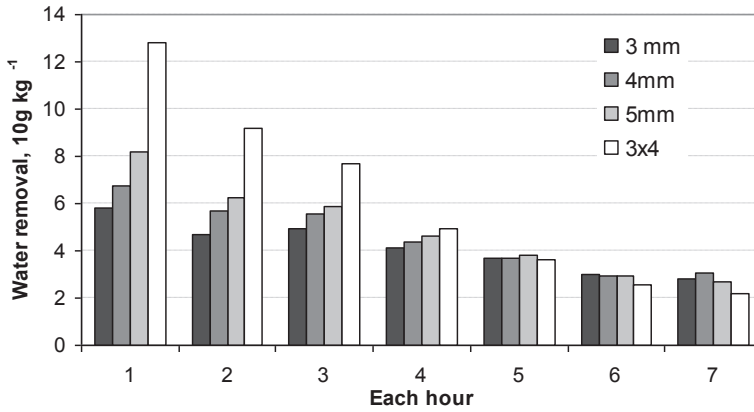

Figure 7. The moisture removal from the manure (10g kg^{-1}) with initial manure moisture 52.4%, at each hour of drying with air speed at bottom 2.04 m s^{-1} .

The results show that the forced air flow significantly increases the drying speed. Free convection is ineffective in manure drying especially during the first hours of drying (Fig. 8).

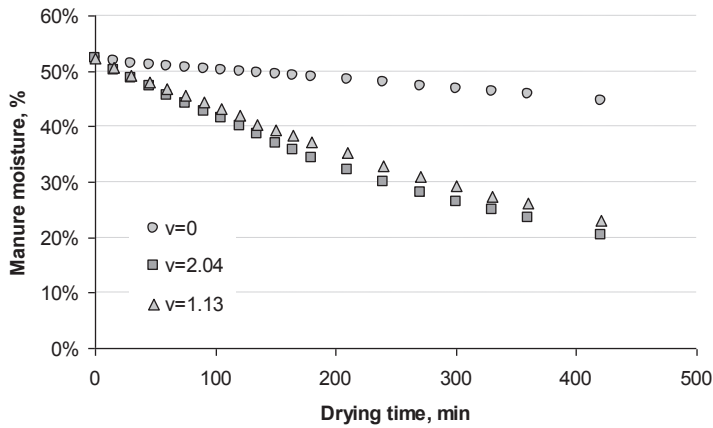

Figure 8. Changes of the manure moisture at tray with holes size 4 mm and with different forced air speeds v (m s^{-1}).

Using the experimental data and according to the methodology described in (Aboltins, 2013), there is in the case of manure drying by forced convection at sieve with mesh 3 x 4 mm with air velocity 1.13 m s^{-1} obtained variable drying coefficient:

$$K(t) = 0.71 \cdot 10^{-5} \cdot t + 39.3 \cdot 10^{-4}, \quad (2)$$

with the coefficient of determination $\eta^2 = 0.89$, where t is the drying time (min).

The theoretical changes of manure weight can be calculated using (1) as

$$W = (W_s - W_p) \cdot \exp\left[-\left(\frac{0.71 \cdot 10^{-5}}{2} t^2 + 39.3 \cdot 10^{-4} \cdot t\right)\right] + W_p, \quad (3)$$

The theoretical and experimental results of changes of manure mass are shown in Fig. 9.

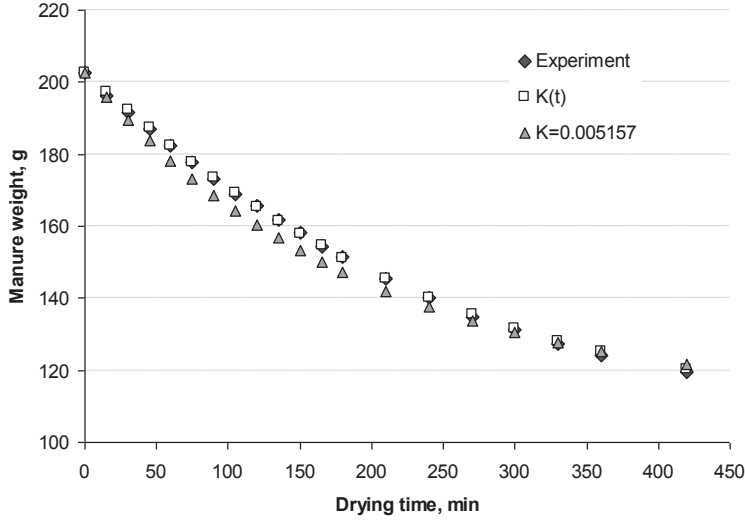

Figure 9. The theoretical (with constant and changing drying coefficients) and experimental changes of manure moisture at sieve with mesh 3 x 4 mm with forced air speed 1.13 m s^{-1} .

The constant drying coefficient was calculated as an average of drying coefficient values at each point of time. The average value of difference between the corresponding theoretical and experimental data was 1 g with standard deviation 0.7 g (for linear $K(t)$) and 2.6 g with standard deviation 1.6 g (for the constant drying coefficient). The equilibrium moisture content of manure in experiment was 16%.

The drying coefficient in the case of manure placed in a tray with holes 5 mm with the forced air by the velocity of 1.13 m s^{-1} , was

$$K(t) = 0.23 \cdot 10^{-5} \cdot t + 27.77 \cdot 10^{-4}, \quad (4)$$

with the coefficient of determination $\eta^2 = 0.88$, with holes 4 mm was

$$K(t) = 0.22 \cdot 10^{-5} \cdot t + 23.23 \cdot 10^{-4}, \quad (5)$$

with the coefficient of determination $\eta^2 = 0.95$ and with holes 3 mm

$$K(t) = 0.2 \cdot 10^{-5} \cdot t + 19.1 \cdot 10^{-4}, \quad (6)$$

with the coefficient of determination $\eta^2 = 0.93$.

According to the equations (4–6) the hole diameter does not significantly affect the drying rate dependence on the time. Diameters have a significant impact at the beginning of drying process, which is characterized by free expression members at equations (4–6). Comparing the expressions (4–6) with (2) it is obvious that the tray with the sieve significantly increases the drying rate dependence of the time. This effect is more than 3 times larger than with the trays with holes.

CONCLUSIONS

This research was useful for verification of the method for calculation of a drying coefficient in a thin layer of material for very special materials, like poultry manure. It has been found that the air flow has a strong influence on drying time, but the shape and dimensions of holes are not important from this point of view. The free convection is not efficient for the poultry drying.

In order to achieve the suitable moisture of manure for following applications with economic benefits, the optimization of drying time should be provided and respected.

Future research in this area of research should be focused on the study of other factors influencing the drying process partly described and expressed by drying coefficient.

REFERENCES

- Aboltins, A. 2013. Theoretical study of material drying coefficient. In Vartukapteinis, K.: *12th International Scientific Conference Engineering for Rural Development*. Latvia University of Agriculture, Jelgava, pp. 153–158.
- Aboltins, A., & Palabinskis, J. 2013. New types of air heating solar collectors and their use in drying agricultural products. *Agronomy Research* **11**, 267–274.
- Council Directive 1999/74/EC of 19 July 1999 laying down minimum standards for the protection of laying hens. Official Journal of the European Communities L 203/53
- Chiumenti, R., Da Borso & Guercini, S. 1993. *Technical guide for the management of livestock manure*. Provincia di Padova, Padova, 160 pp. (In Italian)
- Chiumenti, R. 2004. *Rural buildings*. Edagricole scolastico, Milano, 479 pp. (In Italian)
- De Gobbi, R., Mezzalana, G., Santacroce, F.C. & Ruol, G. 2012. *Nitrates from problem to resource*. Veneto Agricoltura, Azienda Regionale per i Settori Agricolo, Forestale e Agroalimentare, Legnaro, 150 pp. (In Italian)
- Jokiniemi, T., Mikkola, H., Rossner, H., Talgre, L., Lauringson, E., Hovi, M. & Ahokas, J. 2012. Energy savings in plant production. *Agronomy Research* **10**, 85–96.
- Jokiniemi, T., Jaakkola, S., Turunen, M. & Ahokas, J. 2014. Energy consumption in different grain preservation methods. *Agronomy Research* **12**, 81–94.
- Kic, P. & Liska, R.: *Apparatus for drying loose or bulk materials*. Utility model No. 23841. Industrial property Office, Prague, 2012, 5 pp. (In Czech)
- Kic, P. & Aboltins, A. 2013. Convective drying of poultry manure by different air speeds. In Vartukapteinis, K.: *12th International Scientific Conference Engineering for Rural Development*. Latvia University of Agriculture, Jelgava, pp. 121–125.
- Liska, R. & Kic, P. 2011. Characteristics of drying process of poultry manure at various temperatures. *Scientiaagriculturae Bohemica* **42**, 79–86.
- Pasila, A. 2013. Changes, challenges and opportunities in the wood energy supply chain. *Agronomy Research* **11**, 529–532.